

User Information

Pan Mixer DZ100VS

Store for future reference

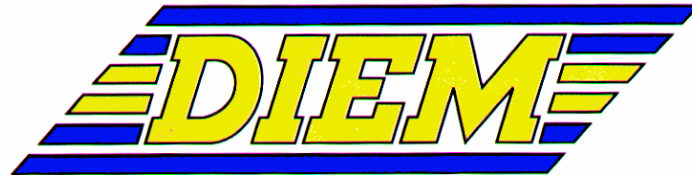

DIEM – WERKE G.m.b.H.
Lindauer Straße 60
A-6911 Lochau

Telephone: +43 / 5574 / 42 8 74

FAX: +43 / 5574 / 46 4 18

Internet: www.diemwerke.com

E-Mail: verkauf@diemwerke.com

Machine data

Designation	Type	Year of construction	Machine no.	Invoice number
High performance pan mixer	DZ100VS			

Trademark, Logo



is the company logo of
Diem-Werke G.m.b.H.

MADE IN AUSTRIA

Issue 01/2007
Version 1.0
Printed in Austria



This mixer complies with the Machine Regulations (98/37/EG) as well as the relevant health and safety requirements.
It is authorised to bear the CE label.

Table of contents

1	Important information	5
2	Fundamental safety instructions	7
2.1	Observe the instructions given in the user information document	7
2.2	Observe all local safety regulations	7
2.3	Safety regulations for mixing chemicals	7
2.4	Protection gear	7
2.4.1	Protection gear for mixing chemicals	7
2.5	Hazards when using the mixer	8
2.6	Warranty and liability	8
2.7	Safety instructions, explanations of symbols	9
2.7.1	Significance of the signal words	9
2.7.2	Significance of hazard symbols	9
2.8	Intended use	10
2.9	Improper usage	10
2.10	Staff training	10
2.11	Service and maintenance, trouble-shooting	10
2.12	Structural modifications	11
2.13	Transportation	11
2.14	Disposal	11
3	Product description	12
3.1	Hazard areas	13
3.2	Safety devices	13
3.3	Conformity	14
3.4	Designation	14
3.5	Area of application	14
3.6	Technical data	15
3.6.1	Dimensions	15
3.6.2	Electrics	16
3.6.3	Ambient conditions	16
4	Transport	17
4.1	Preparations for transportation	17
4.2	Loading/unloading	18
4.3	Transportation	18
4.4	Manually moving the mixer	18
5	Setup, connection	19
5.1	Setup	20
5.2	Connect the electrical cables	20
5.2.1	Characteristics of the electrical connection cables	20
5.2.2	Rotational direction of the mixer	20
5.2.3	Re-connecting the phases	21
5.3	Connect the water supply	21

6	Adjusting the mixer mechanism	22
6.1	Safety regulations	22
6.2	Overview of mixer mechanism	23
6.3	Adjusting the rotating star	23
6.4	Adjusting the sprung floor scraper	24
6.5	Adjust the floor scraper	24
6.6	Adjust the outer scraper	24
7	Operation	25
7.1	Safety instructions	25
7.2	Switch-on / filling	26
7.3	Emptying / switch-off	26
8	Problems, resolving problems	27
8.1	Safety regulations	27
8.2	Problem resolution	28
9	Maintenance / Repair	29
9.1	Safety regulations	29
9.2	Maintenance work	30
9.3	Repair work	30
10	Shutdown and storage	31
10.1	Safety regulations	31
10.2	Shutdown procedure	31
10.3	Storage conditions	32
10.4	Restarting	32
11	Customer service	33
11.1	Service centres	34
12	Wearing parts	35
13	Equipment	36

1 Important information

Documentation

This user information document is intended for persons operating or maintaining the **High-Performance Pan Mixer DZ100VS**, hereinafter simply referred to as "mixer", which is manufactured by the DIEM-WERKE G.m.b.H.

Legend

The significance of the symbols employed in this user information document is as follows:

⇒ Action required:

This symbol is shown whenever an action has to be carried out once the information has been read.

ⓘ Information:

This symbol is used to indicate important information on the use of the mixer.

↳ Numbering symbol

§

Legal note:

This symbol informs the reader that the local country-specific regulations must be observed.

Measures on receipt of the goods

↳ Perform a visual inspection of the mixer on its receipt.

If there are any signs of transportation damage, take the necessary steps as described in the supply contract. Any repair costs must be borne by the forwarding agent insuring the risk.

Storage

Store the mixer to protect it against bad weather or external influences.

Models

If the documentation describes various models, only the information for the supplied model will apply. If the stated information does not explicitly differentiate between models, it will apply in a logical manner to all models. We reserve the right to make any changes prior to delivery which serve to improve the supplied product.

Accident prevention

Ensure compliance with the notes on accident prevention given in the documentation.

§

Any relevant country-specific accident prevention regulations for a given application must also be observed.

The company DIEM-WERKE G.m.b.H. manufactures its products according to current international safety standards. Any specific local regulations must be notified by the customer prior to the start of manufacture. Any additional costs must be borne by the customer.

Copyright

Complete or partial reproduction of this document, its electronic storage or access by third parties are not permitted without the written permission DIEM-WERKE G.m.b.H..

Guarantee

Guarantees are given within the scope of the contractual agreement. It is a pre-requisite that only original spare parts are used. Damages through improper use, non-compliance with our regulations or incorrect operation by unauthorised personnel will void any guarantee claim.

Structure of this user information document

This manual should facilitate rapid and easy operation of the described mixer and serve as a document for future reference. This user information document is intended for trained personnel and serves to provide assistance during startup, operation, service or repair work.

The table of contents at the start of this document allows the required section to be quickly located.

Read this user information document so you become familiar with the particular model of mixer.

Observe all safety instructions. They should help prevent accidents and damages.

2 Fundamental safety instructions

2.1 Observe the instructions given in the user information document

A basic pre-requisite for safe usage and fault-free operation of the described mixer is knowledge of the fundamental safety instructions and safety regulations.

This user information document, in particular the safety instructions, must be observed by all persons working with the mixer.

Furthermore ensure compliance with the relevant local rules and regulations on accident prevention.

2.2 Observe all local safety regulations

§ In addition to the safety regulations specified in these instructions, also ensure compliance with any country-specific regulations relating to the use of the mixer in a specific application.

2.3 Safety regulations for mixing chemicals

Before mixing chemicals, obtain details on the required safety measures from the manufacturer of the materials being mixed. Also ensure compliance with any country-specific regulations.

2.4 Protection gear

The operator must wear the following protection gear when operating the mixer:

- ↳ Safety shoes
- ↳ Protective goggles
- ↳ Hairnet or headgear to prevent hair being pulled on
- ↳ Ear protection
- ↳ Breathing protection (heavy dust generation during mixing)

2.4.1 Protection gear for mixing chemicals

Before mixing chemicals, obtain details on the required protection gear from the manufacturer of the materials being mixed. Also ensure compliance with any country-specific regulations.

2.5 Hazards when using the mixer

The mixer has been manufactured using state-of-the-art technology and in accordance with recognised safety-related guidelines. However, when using the mixer there is a risk of (fatal) injury to the user or third persons as well as material damage.



Only use the mixer:

- ↳ for its intended application (see chapter 2.8)
- ↳ when it is in a perfectly safe state
- ↳ when operated by persons above 16 years of age
- ↳ in conjunction with the specified protection gear



The operator is responsible for ensuring the safety of children in the vicinity of the mixer!

2.6 Warranty and liability

In principle our "General Sales and Delivery Conditions" apply. These are provided to the operator no later than the point at which the contract is finalised. Warranty and liability claims for personal or material damage are not covered if caused by one of the following:

- ↳ usage other than that for which it is intended
- ↳ improper installation, startup, operation and maintenance
- ↳ Working with a damaged mixer
- ↳ Non-observance of the instructions in the user information document concerning transportation, storage, installation, startup, operation and maintenance
- ↳ unauthorised mechanical modifications
- ↳ inadequate monitoring of components which are subject to wear
- ↳ improper repair work
- ↳ catastrophes due to effects/influences from extraneous elements and force majeure

2.7 Safety instructions, explanations of symbols

The hazard symbols always appear together with a signal word. The signal words indicate the extent of the hazard. Carefully read the safety instructions. They play a major role in safe usage of the mixer and help prevent the occurrence of faults which could have severe consequences for persons as well as the equipment itself.

2.7.1 Significance of the signal words

Hazard!

Hazard which threatens immediate danger.

Non-observance of this instruction can result in serious, life-threatening or even fatal injuries.

Warning!

Potential threat of danger.













Non-observance of these instructions can result in serious, life-threatening or fatal injuries as well as material damage.

Caution!

Potential threat of danger.

Non-observance of these instructions can result in injuries or material damage.

2.7.2 Significance of hazard symbols

	General hazard		Inhalation of dangerous dusts and vapours
	Electric shock		Prohibited for unauthorised persons
	Risk of crushing for whole body		Wear safety shoes
	Uncontrolled movements during transportation		Wear a hardhat
	Toppling parts		Wear head, ear and eye protection
	Severance and crushing of body parts		Observe disposal regulations

2.8 Intended use

The DZ100VS mixer should only be used to mix the following materials:

- ↳ Ready mix (concrete, mortar; granularity max. 32mm)
- ↳ Chemicals (powder- or granulate-based)
- ↳ Oil sludge

Any other application is not permitted.

The definition of intended use also includes:

- ↳ Observance of accident prevention regulations
- ↳ Observance of all instructions in the user information document
- ↳ Performing all the required inspection and maintenance tasks

2.9 Improper usage

The mixer should **not** be used to mix the following materials:

- ↳ mixes which are explosive or aggressive to metals

All applications other than those listed in section 2.8 are prohibited. DIEM-WERKE G.m.b.H will not accept liability for any consequential damages.

Improper usage may result in hazards which are not fully covered by the safety measures.

2.10 Staff training

Only trained and briefed staff with the necessary experience are allowed to operate the mixer.

Trainee staff are only allowed to operate the mixer under the supervision of an experienced person.

2.11 Service and maintenance, trouble-shooting

- ↳ Perform the specified adjustment, maintenance and inspection tasks at the required intervals.
- ↳ Always disconnect the mixer from the voltage supply when performing any maintenance, inspection and repair work.
- ↳ Position the mixer on solid ground when performing any maintenance, inspection and repair work..
- ↳ Verify that any previously loosened screw fittings are tight.
- ↳ Check the function of safety devices after the maintenance work has been completed.

2.12 Structural modifications

- ↳ Modifications should only be performed by the manufacturer.
- ↳ Immediately replace any parts which are not in an acceptable condition.
- ↳ Only use original spare parts and wearing parts.
- ↳ Third-party components do not necessarily fulfil the structural and safety requirements in terms of design and manufacture.
- ↳ The manufacturer is only liable for subsequently installed additional fittings if he has performed these modifications himself.
- ↳ The equipment must be restored to its original state when any additional fittings are removed.

2.13 Transportation

- ⓘ Use suitable means to prevent the mixer from sliding or toppling during transportation.

2.14 Disposal

- ⓘ Immediately make any disused mixer inoperative and label accordingly!



Observe disposal regulations!

Observe all country-specific regulations for the disposal of

- ↳ the mixer
 - ↳ mixer components
 - ↳ oils, greases and other auxiliary materials
 - ↳ cleaning agents
 - ↳ packaging material
 - ↳ building materials
-

3 Product description

The DZ100VS mixer has the following characteristics:

- ↳ High-performance pan mixer for 100 litres of ready mix
- ↳ with transportation handle for manual movement
- ↳ solid steel sub-frame
- ↳ Mixing mechanism manufactured from wear-resistant steel
- ↳ Drive system using a three-phase or single-phase motor via a directly flanged and maintenance-free spur gear unit
- ↳ Mix materials and liquids are loaded directly from above through a closed safety guard
- ↳ Emptied through a segment slider opening in the floor
- ↳ Simple handling:
 - ↳ only one switch
 - ↳ Universal stirring mechanism, 0 ...32 mm granularity
 - ↳ The mixing mechanism and outer scrapers may be adjusted to the required granularity using an open-ended spanner (size 17)
 - ↳ may be readjusted in case of wear



1	Safety guard	7	Transport handle
2	Eyebolts	8	EMERGENCY-OFF button
3	Mixing mechanism	9	CEE socket
4	Interlock	10	Connection for water supply
5	Emptying slider	11	Safety end-switch (covered)
6	Emptying protection		

Tab. 1 Overview

3.1 Hazard areas

The operator must ensure that no unauthorised persons are in the vicinity of the mixer during operation! He is also responsible for any third parties that may be present.

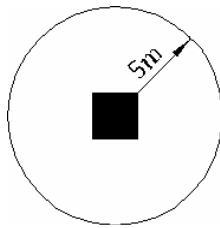

PROTECTION ZONE: 5 metres

3.2 Safety devices

The Tab. 2 specified parts serve to ensure the safety of personnel operating the mixer.

- ⚠ Damaged or faulty safety devices must be immediately replaced by original manufacturer spare parts.
- ⚠ It is prohibited to operate the mixer using faulty or damaged safety devices.
- ⚠ It is forbidden to disable any of the safety devices.



Tab. 2 Safety devices

3.3 Conformity

The machine conforms to EU Directive 98/37/ECC Annex II A and the Machinery Safety Order – Federal Law Gazette No. 306/1994

In formulating the safety concept, the following standards were also taken into account.

73/23/EEC	Low Voltage Directive
89/336 EEC	Electromagnetic compatibility
EN 12100-1	Safety of machinery. Basic concepts, general principles for design. Basic terminology, methodology
EN 12100-2	Safety of machinery – Basic concepts, general principles for design – Part 2: Technical principles and specifications
EN 418	Safety of machinery – Emergency stop equipment, functional aspects – Principles for design
EN 60204-1	Safety of machinery – Electrical equipment of machines – Part 1: General requirements

3.4 Designation

The identification plate is located near the switchbox.



Fig. 1 Position of identification plate

3.5 Area of application

See chapter 2.8 "Intended use".

3.6 Technical data

Mixer drum		
Drum capacity:	[l]	146
Mixer capacity:	[l]	100
Drum diameter:	[mm]	696
Drum height:	[mm]	370
Water connection:	"	¾
Mixing mechanism		
Speed:	[rpm]	40
Gears		
Type Diem SG40C-VS100		

3.6.1 Dimensions

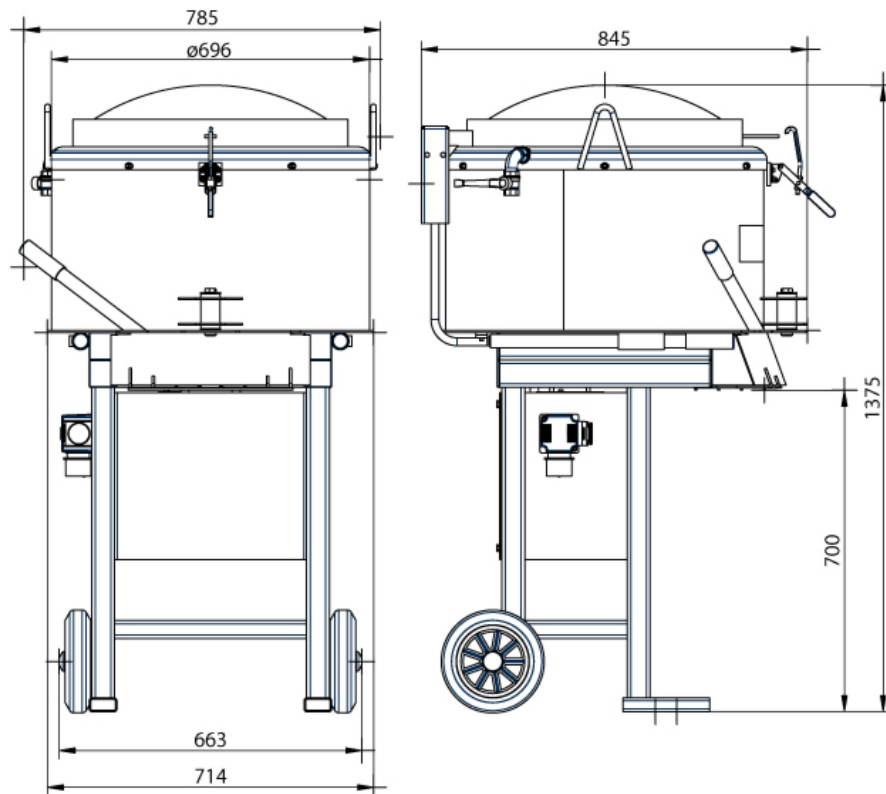

Fig. 2 Dimensions

Length:	[mm]	845
Width:	[mm]	785
Height:	[mm]	1375
Weight:	[kg]	ca. 203
Filling height:	[mm]	1375
Emptying height:	[mm]	700

3.6.2 Electrics

		Low voltage	High voltage
Operating voltage:	[V]	230	3x400
Frequency:	[Hz]	50	50
Nominal power:	[kW]	2.0	2.2
Protection degree:		IP54	IP54

3.6.3 Ambient conditions

Illumination min.:	[lx]	200
Temperature max.:	[°C]	50
Temperature min.:	[°C]	-20
Air humidity max.:	[%]	90
Noise pressure level idle running:	[dB(A)]	30
Noise pressure level operation:	[dB(A)]	60

4 Transport



Warning!

Uncontrolled movements during transportation!

Serious injuries

if trapped or crushed.

⇒ Do not walk under suspended loads

⇒ Only lift the mixer by the eyebolts

⇒ Completely empty the mixer prior to transportation



Warning!

Toppling mixer!

Serious injuries

if trapped or crushed.

⇒ Secure the mixer against toppling or sliding during transportation



Warning!

Unqualified personnel!

Risk of injury

if incorrect transportation procedure is used.

⇒ The mixer should only be transported by personnel with experience in handling and transporting the mixer.

⇒ Unqualified persons should only perform transportation work if supervised by experienced personnel.



Wear safety shoes!

Always wear safety shoes when transporting the mixer.



Wear hardhat!

Always wear a hardhat when transporting the mixer.

4.1 Preparations for transportation

- ⇒ Completely empty the mixer.
- ⇒ Disconnect the mixer from the voltage supply.
- ⇒ Wind up the connection cable.
- ⇒ Disconnect the mixer from the water supply.
- ⇒ Close the segmental arch opening.
- ⇒ Close and lock the safety guard.

4.2 Loading/unloading

- ⇒ Attach the mixer to the crane using the eyebolts.
- ⇒ Slowly raise the crane hook until the crane straps are tensioned.
- ⇒ Take several steps back from the mixer.
- ⇒ Lift the mixer.
- ⇒ Put down the mixer.
- ⇒ Detach the mixer from the crane.

4.3 Transportation

- ⇒ Use belts to secure the mixer against toppling or sliding during transportation.

4.4 Manually moving the mixer

- ⇒ Perform the transportation preparations as described in chapter 4.1.
- ⇒ Extend the transportation handles.
- ⇒ Two persons should pull the mixer by its transport handles to the required location.
- ⇒ Ensure that the mixer is standing securely.
- ⇒ Insert the transport handles.

5 Setup, connection



Hazard!

Electrical connections!

Fatal
electric shock hazard.

- ⇒ Only work on the electrical components of the mixer when the connection cables have been unplugged.
 - ⇒ Immediately replace any faulty or damaged connection cables.
-



Warning!

Toppling mixer!

Serious injuries
if trapped or crushed.

- ⇒ Always set up the mixer on level and solid ground.
-



Warning!

Unqualified personnel!

Risk of injury
if incorrect setup procedure is used.

- ⇒ The mixer should only be set up by personnel with the necessary experience in handling the mixer.
 - ⇒ Unqualified personnel are only permitted to use the mixer under the supervision of experienced personnel.
-



Wear safety shoes!

Always wear safety shoes when setting up the mixer.



Wear hardhat!

Always wear a hardhat when setting up the mixer.

5.1 Setup

The mixer must be set up on solid and level ground.
Keep clear the protection zone of 5 metres around the mixer.

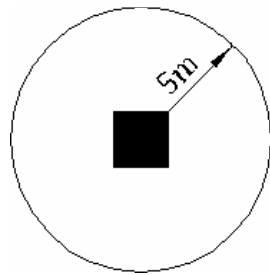

PROTECTION ZONE: 5 metres

5.2 Connect the electrical cables



Warning!

Unqualified personnel!

Risk of injury

if the electrical cables are not connected correctly.

⇒ The mixer should only be connected by personnel with the necessary experience in handling the mixer.

⇒ Unqualified personnel are only permitted to use the mixer under the supervision of experienced personnel.



Caution!

Legal note!

⇒ The electric circuit, to which the mixer is connected, has to be protected with a residual current circuit-breaker!

5.2.1 Characteristics of the electrical connection cables

§ Take into account the country-specific regulations concerning the characteristics of the electrical connection cable.

Example of an electrical connection:

- ↳ Rubber tubing cables HO7RN-F (DIN 57282 Part 1 / VDE 0282 Part 1)
- ↳ Flexible cables with polyurethane coating (DIN 57250 / VDE 0350 Part 818)

Cross-section: at least 2.5 mm²

5.2.2 Rotational direction of the mixer

The rotational direction of the mixer arms must correspond to the direction of the arrow on the mixer drum.

If the rotational direction opposes the arrow, the phases of the connection cable must be connected in a different order. Details on re-connecting the phases are given in chapter 5.2.3.

5.2.3 Re-connecting the phases



Hazard!

Exposed electrical contacts!

Fatal electric shock hazard.

⇒ Disconnect the connection cable from the voltage supply before re-connecting the terminals.

- ⇒ Detach the connection cable from the voltage supply.
- ⇒ Use a screwdriver to change the phases (see Fig. 3.).

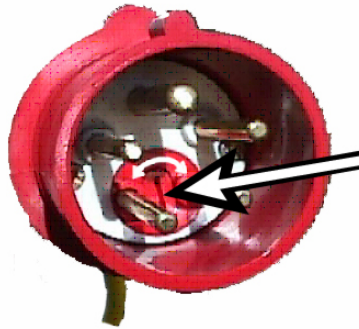

Fig. 3 Phase changer

5.3 Connect the water supply

- ⇒ Close the ball valve on the water connection (Fig. 4).
- ⇒ Attach the water hose to the water connection ($\frac{3}{4}$ ").
- ⇒ Open the water tap for the water supply.
- ⇒ Check the water connection is tight.
- ⇒ If necessary seal any leaks in the water connection.



Fig. 4 Position of water connection

6 Adjusting the mixer mechanism

 The mixer mechanism must be adjusted to the granularity of the materials being mixed.

6.1 Safety regulations



Warning!

Unexpected start-up!

Serious injuries
if trapped or crushed.

⇒ Before adjusting the mixer mechanism, switch off the mixer at the main circuit breaker and attach a padlock to prevent it being switched back on.



Warning!

Toppling mixer!

Serious injuries
if trapped or crushed.

⇒ Set up the mixer on level and solid ground.



Warning!

Unqualified personnel!

Risk of injury
if incorrect adjustment procedure is used.

⇒ The mixer mechanism should only be adjusted by personnel with the necessary experience in handling the mixer.

⇒ Unqualified personnel are only permitted to use the mixer under the supervision of experienced personnel.

6.2 Overview of mixer mechanism

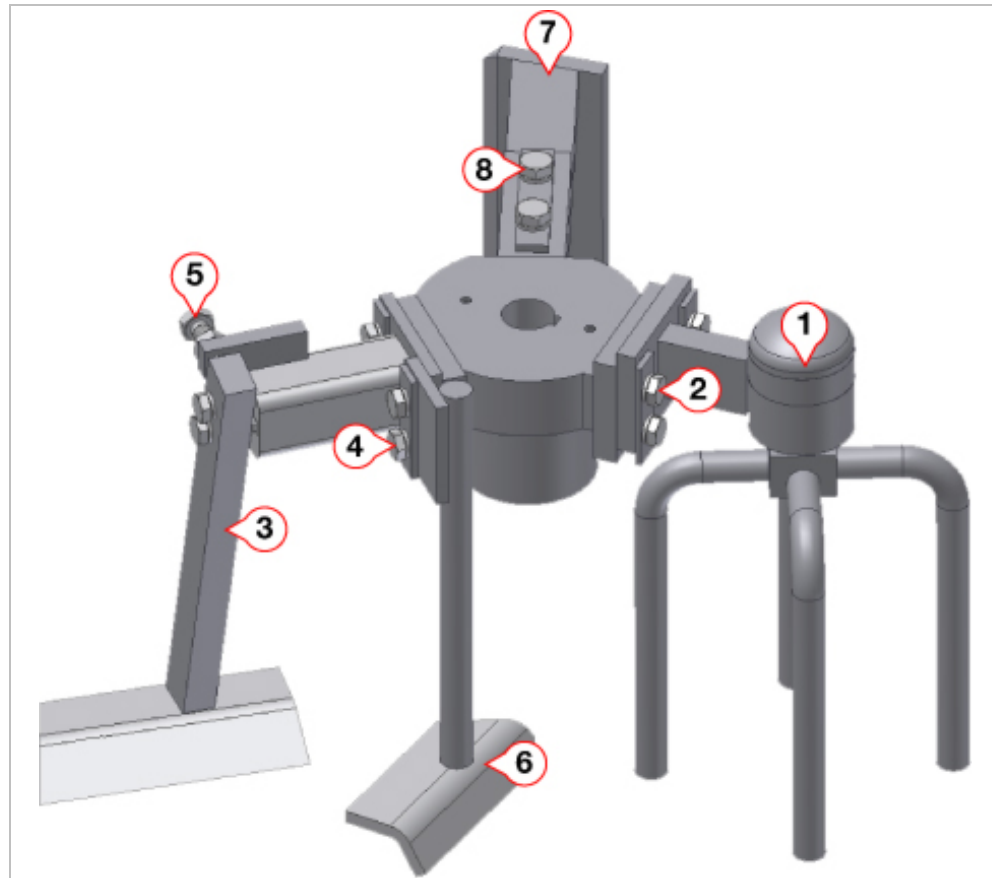

1	Rotating star	5	Adjustment screw
2	Fixing screws	6	Floor scraper
3	Sprung floor scraper	7	Outer scraper
4	Fixing screws	8	Fixing screws

6.3 Adjusting the rotating star

i Distance from the rotating star to the floor of the mixer drum = largest granularity + 5mm.

- ⇒ Undo fixing screws (2) for rotating star (1).
- ⇒ Adjust the floor clearance.
- ⇒ Tighten fixing screws (2).

6.4 Adjusting the sprung floor scraper

Setting the pre-stressing force

- ⇒ Undo the counter nut on adjustment screw (5).
- ⇒ Tighten the adjustment screw until the sprung floor scraper exerts sufficient force.
- ⇒ Tighten the counternut.

Adjusting the scraper

- ⇒ Undo fixing screws (4) for floor scraper (3).
- ⇒ Adjust the sprung floor scraper until it has approx. 1-3 mm clearance to the floor of the drum.
- ⇒ Tighten the fixing screws.

6.5 Adjust the floor scraper

- ⇒ Undo fixing screws (4) for floor scraper (6).
- ⇒ Adjust the floor scraper by sliding it along the slotted holes until it has approx. 1-3 mm clearance to the floor of the drum.
- ⇒ Tighten the fixing screws.

6.6 Adjust the outer scraper

- ⇒ Undo fixing screws (8) for outer scraper (7).
- ⇒ Adjust the outer scraper until it lightly brushes against the wall of the drum.
- ⇒ Tighten the fixing screws.

7 Operation

7.1 Safety instructions



Warning!

Dust and vapours!

Health risk, risk of asphyxiation due to the inhalation of toxic dust and vapours.

⇒ Use dust cover, vacuum extraction or breathing protection when mixing dry materials



Warning!

Mixing chemicals!

Risk of death

due to an unexpected reaction when mixing chemicals.

⇒ Before mixing chemicals obtain information on the relevant safety regulations (protection gear, ambient conditions).

⇒ Ensure compliance with the relevant safety regulations on mixing chemicals.



Warning!

Exposed rotating parts!

Serious injuries

if trapped or crushed.

⇒ Only operate the mixer when all safety devices are fully functional.

⇒ Only operate the mixer when the safety guard is closed.



Warning!

Toppling mixer!

Serious injuries

if trapped or crushed.

⇒ Set up the mixer on level and solid ground.



Warning!

Unqualified personnel!

Risk of injury

if the mixer is incorrectly operated.

⇒ The mixer should only be operated by personnel with the necessary experience in handling the mixer.

⇒ Unqualified personnel are only permitted to use the mixer under the supervision of experienced personnel.



Wear safety shoes!

Always wear safety shoes when operating the mixer.



Wear protection gear!

Wear a hardhat as well as eye and ear protection when operating the mixer.

7.2 Switch-on / filling



Caution!

Starting up with a filled mixer drum!

Risk of damage to the machine
due to difficult start-up.

⇒ Only fill the materials being mixed after the mixer is switched on.

- ⇒ Open the switchbox (Fig. 5).
- ⇒ Press the green button.
- ⇒ Fill the mix materials.

7.3 Emptying / switch-off

- ⇒ Open the segmental arch opening by operating the emptying lever.
- ⇒ Emptying the mixer.
- ⇒ Press the red button on the switchbox(Fig. 7).
- ⇒ Use a padlock to secure the switchbox.
- ⇒ Clean the mixer.
- ⇒ Close the segmental arch opening by operating the emptying lever.



Fig. 5 Open the switchbox



Fig. 6 Switchbox operation



Fig. 7 Switchbox closed

8 Problems, resolving problems

8.1 Safety regulations



Hazard!

Electrical connections!

Fatal
electric shock hazard.

- ⇒ Only work on the electrical components of the mixer when the connection cables have been unplugged.
- ⇒ Immediately replace any faulty or damaged connection cables.
- ⇒ Work requiring expert knowledge should only be carried out by specialist workshops.



Warning!

Toppling mixer!

Serious injuries
if trapped or crushed.

- ⇒ Always set up the mixer on level and solid ground.



Warning!

Unexpected start-up!

Serious injuries
if trapped or crushed.

- ⇒ Before working on the mixer mechanism, switch off the mixer at the main circuit breaker and attach a padlock to prevent it being switched back on.



Warning!

Unqualified personnel!

Risk of injury
if correct trouble-shooting procedure is not followed.

- ⇒ Problem resolution work should only be carried out by persons with the necessary experience in handling the mixer.
- ⇒ Unqualified personnel are only permitted to use the mixer under the supervision of experienced personnel.



Always wear safety shoes!

8.2 Problem resolution

Problem	Possible cause	Rectification
Motor will not run	No supply voltage	⇒ Check fuse ⇒ Switch main circuit breaker to 1 ⇒ Phases should be checked by an electrician
	Safety guard open	⇒ Close safety guard
	Over- or undervoltage switch has tripped	⇒ Open and re-close the main circuit breaker
	Overload	⇒ Switch off the main circuit breaker ⇒ Let the motor cool down ⇒ Switch on the main circuit breaker
	Faulty connection cable, connector or coupling	⇒ Check by an electrician
Overheating motor, decreased performance or motor comes to standstill	Motor only runs on 2 phases	⇒ Switch off the machine ⇒ The connection cable should be checked by an electrician
Whistling noise during mixing	Mixer mechanism not set to the right granularity	⇒ Adjust the mixer mechanism (see chapter 6)

9 Maintenance / Repair

9.1 Safety regulations



Warning!

Unexpected start-up!

Serious injuries
if trapped or crushed.

- ⇒ Before adjusting the mixer mechanism, switch off the mixer at the main circuit breaker and attach a padlock to prevent it being switched back on.



Hazard!

Electrical connections!

Fatal
electric shock hazard.

- ⇒ Only perform maintenance and repair work when the connection cable is unplugged.
- ⇒ Work requiring expert knowledge should only be carried out by specialist workshops.



Warning!

Toppling mixer!

Serious injuries
if trapped or crushed.

- ⇒ Set up the mixer on level and solid ground.



Warning!

Rotating parts!

Serious injuries
if trapped or crushed.

- ⇒ Do not reach inside the emptying opening when the mixer is switched on.



Warning!

Unqualified personnel!

Risk of injury
if incorrect maintenance procedure is used.

- ⇒ Maintenance work should only be carried out by persons with the necessary experience in handling the mixer.
- ⇒ Unqualified personnel are only permitted to use the mixer under the supervision of experienced personnel.



Wear safety shoes!

Always wear safety shoes when operating the mixer.



Wear protection gear!

Wear a hardhat as well as eye and ear protection when operating the mixer.

9.2 Maintenance work

i The timely replacement of wearing parts will avoid unnecessary downtimes and poor mixing results.

Part	Maintenance task	before usage	after usage.
Complete mixer	Clean		X
	Check safety devices	X	
Floor scraper	Check settings; adjust or replace if worn	X	
Outer scraper	Check settings; adjust or replace if worn	X	

9.3 Repair work

i Repairs should only be carried out by authorised specialist workshops.

10 Shutdown and storage

10.1 Safety regulations



Warning!

Uncontrolled movements during transportation!

Serious injuries
if trapped or crushed.

- ⇒ Do not walk under suspended loads.
- ⇒ Only lift the mixer by the eyebolts.
- ⇒ Completely empty the mixer prior to transportation.



Warning!

Toppling mixer!

Serious injuries
if trapped or crushed.

- ⇒ Secure the mixer against toppling or sliding during transportation.



Warning!

Unqualified personnel!

Risk of injury
if incorrect transportation procedure is used.

- ⇒ The mixer should only be shutdown by personnel with the necessary experience in handling the mixer.
- ⇒ Unqualified personnel are only permitted to use the mixer under the supervision of experienced personnel.



Wear safety shoes!

Always wear safety shoes when transporting the mixer.



Wear hardhat!

Always wear a hardhat when transporting the mixer.

10.2 Shutdown procedure

- ⇒ Completely empty the mixer.
- ⇒ Disconnect the mixer from the voltage supply.
- ⇒ Wind up the connection cable.
- ⇒ Disconnect the mixer from the water supply.
- ⇒ Clean the mixer.
- ⇒ Close the segmental arch opening and safety guard.

10.3 Storage conditions

- ↳ Store the mixer in a location (warehouse) protected against the weather.
- ↳ Store the mixer in a safe location which is not accessible to unauthorised persons.
- ↳ The mixer should be stored in a stable position.
- ↳ Grease all moving parts.
- ↳ Cover the mixer with a thin film of oil during long storage periods (winter).

10.4 Restarting

 Verify the complete functionality of the mixer before starting it up again.

Check the following:

- ↳ Safety devices must be functioning
- ↳ Connecting cables are not damaged

Restarting procedure, see chapter 5.

11 Customer service

If you require assistance:

⇒ Copy this page.

⇒ Please fill in the tables.

The more information we receive, the greater the chance of providing a correct diagnosis and rapid service.

⇒ Fax this copy to:

DIEM - Werke G.m.b.H. , +43 / 5574 / 46418

or your nearest customer service centre (see next page).

Mixer:

Type:

Year of construction:

Invoice – No.:

Purchase date:

Problem description:

Sent by:

Company:

Contact person:

Department:

Address:















.....

Telephone:

Fax:

E-mail:

11.1 Service centres

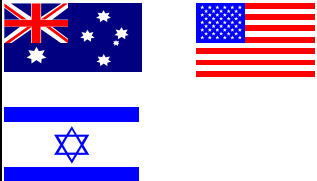
	<p>At the time of print, service centres are available in the countries below. Please call us on +43 / 5574 / 42874 to obtain the address of your nearest service centre.</p>
	<p>HEADQUARTERS</p> <p>DIEM - Werke G.m.b.H. Lindauer Straße 60 A - 6911 Lochau</p> <p>Tel: +43 / 5574 / 42874 Fax: +43 / 5574 / 46418 E-mail: diem@diemwerke.com</p>
	<p>Belgium</p>
	<p>Germany</p>
	<p>Finland</p>
	<p>France</p>
	<p>Great Britain</p>
	<p>Ireland</p>
	<p>Norway</p>
	<p>Austria</p>
	<p>Sweden</p>
	<p>Switzerland</p>
	<p>Spain</p>
	<p>Hungary</p>
	<p>OTHER COUNTRIES Australia, Israel, Far East, USA</p>

12 Wearing parts

Ordering wearing parts:

- ⇒ Copy this page.
- ⇒ Place an x next to the required wearing part in the first column.
- ⇒ Enter the number of required wearing parts in the last column.
- ⇒ Fax this copy to:

DIEM - Werke G.m.b.H. , +43 / 5574 / 46418
or your nearest customer service centre (see page 34).

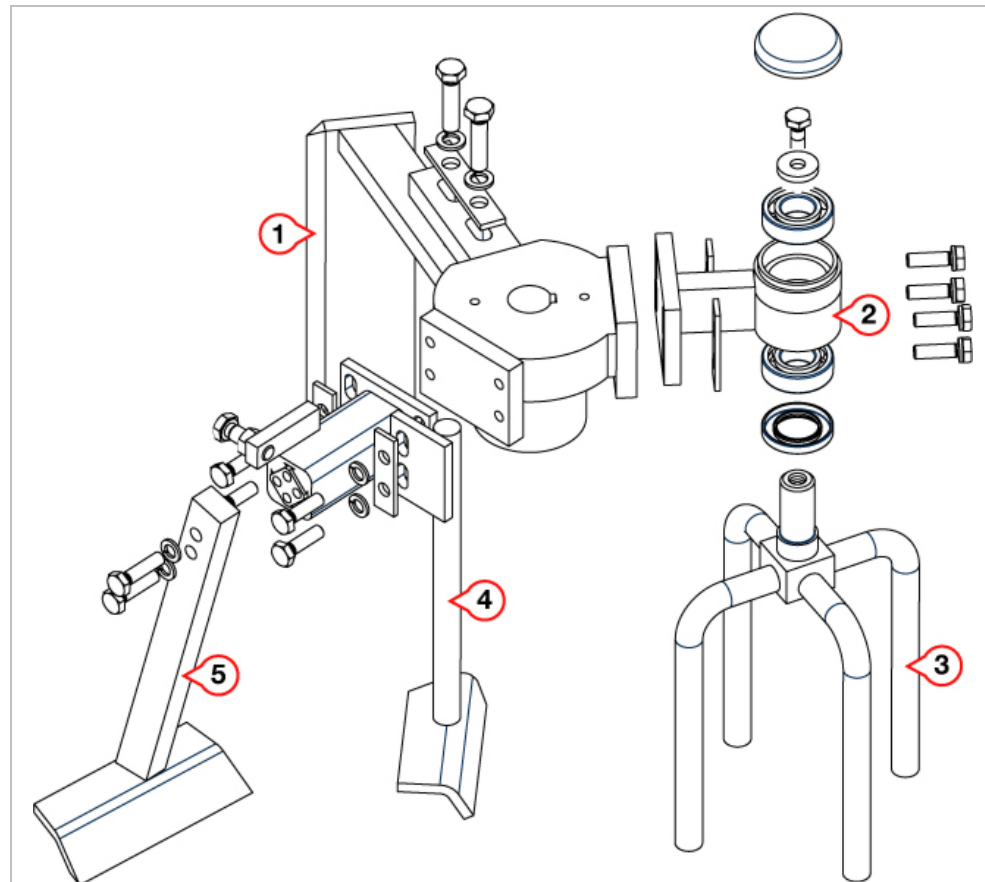

X	Pos.	Part. No.	Designation	Qty.
	1	19317	Outer scraper complete, DZ100VS	
	2	12290	Pillow block for rotating star, DZ100VS	
	3	19310	Rotating star complete, DZ100VS	
	4	19314	Floor scraper complete, DZ100VS	
	5	19311	Floor scraper sprung, DZ100VS	

13 Equipment

Please place your order of equipment directly to the nearest service centre (see chapter 11.1 Service centres).

i The installation of the equipment has to be done or checked by DIEM-WERKE G.m.b.H. or an authorised service centre.



Dust cover

Machine	Part.No.
DZ60VS	20671
DZ100VS	16248
DZ120V	10755
DZ120VB/VD	14016
DZ180V	14009
DZ180VB/VD	15890
DZ180VA	14304
DZ300V	10764
DZ300VA	14305
DZ500V	15888
DZ750V	16688