



KERN & Sohn GmbH

Ziegelei 1
72336 Balingen-Frommern
Germany

www.kern-sohn.com

+0049-[0]7433-9933-0

+0049-[0]7433-9933-149

info@kern-sohn.com

Operating instructions Platform balance

KERN DS

Type TDS-A

Version 1.0

2022-08

GB



TDS-BA-e-2210



KERN DS

Version 1.0 2022-08

Operating instructions Platform balance

Content

1	Technical data.....	4
2	Declaration of conformity	9
3	Appliance overview	10
3.1	Components	10
3.2	Operating elements	11
3.2.1	Keyboard overview.....	11
3.2.2	Numeric entry.....	12
3.2.3	Overview of displays	12
4	Basic Information (General)	13
4.1	Proper use.....	13
4.2	Improper Use.....	13
4.3	Warranty.....	13
4.4	Monitoring of Test Resources.....	14
5	Basic Safety Precautions	14
5.1	Pay attention to the instructions in the Operation Manual	14
5.2	Personnel training.....	14
6	Transport and storage.....	14
6.1	Testing upon acceptance	14
6.2	Packaging / return transport	14
7	Unpacking, Installation and Commissioning.....	15
7.1	Installation Site, Location of Use	15
7.2	Unpacking and checking	16
7.3	Assembling, Installation and Levelling.....	16
7.4	Mains connection.....	16
7.5	Rechargeable battery operation (optional)	17
7.5.1	Load rechargeable battery	17
7.6	Connection of peripheral devices	18
7.7	Initial Commissioning.....	18

7.8	Adjustment	18
7.8.1	External adjustment < CALHE >.....	19
7.8.2	External adjustment with user-defined adjustment weight < CALEd >.....	20
7.8.3	Gravitational constant adjustment location < GRAAdj >.....	22
7.8.4	Gravitational constant adjustment location < GRAAdj >.....	23
8	Basic Operation	24
8.1	Turn on/off	24
8.2	Simple weighing	24
8.3	Zeroing	25
8.4	Taring	25
8.5	Switch-over weighing unit.....	26
8.6	Under-floor weighing (optional, varies by model)	27
9	Operating concept.....	28
10	Application <Weighing>	30
10.1	Application-specific settings	30
10.2	Description of individual functions	31
10.2.1	Take over the placed weight as PRE-TARE value.....	31
10.2.2	Enter the known tare weight numerically < PRE-TARE → PARAL >.....	32
10.2.3	Data-Hold function < HOLD >	32
10.2.4	Percent weighing.....	33
10.2.5	Weighing with multiplication factor.....	34
10.2.6	Molar weighing mode	35
10.3	Quick change key -	36
10.3.1	Weighing Units.....	36
10.3.2	Application units.....	37
11	Application <Counting>.....	38
11.1	Application-specific settings	38
11.2	Using the application.....	39
11.2.1	Piece counting.....	39
11.2.2	Check counting	41
12	Application <Checkweighing>.....	44
12.1	Application-specific settings	44
12.2	Using the application.....	45
12.2.1	Target weighing.....	45
12.2.2	Checkweighing.....	48
13	Menu.....	50
13.1	Navigation in the menu.....	50

13.2	Application menu.....	50
13.3	Setup menu.....	51
13.3.1	Overview < ኃይድሆ >.....	51
14	Communication with peripheral devices via KUP connection	55
14.1	KERN Communications Protocol (KERN Interface Protocol)	56
14.2	Issue functions	57
14.2.1	Add-up mode < sum >.....	57
14.2.2	Data output after pressing the PRINT button < ጠጠሥጠጢ >	59
14.2.3	Automatic data output < ለሆኑ >	60
14.2.4	Continuous data output < ርዕኑ >	60
14.3	Data format	61
15	Servicing, maintenance, disposal	62
15.1	Cleaning.....	62
15.2	Servicing, maintenance	62
15.3	Disposal	62
16	Instant help for troubleshooting.....	63
17	Error messages	64

1 Technical data

KERN	DS 3K0.01S	DS 5K0.05S	DS 8K0.05
Item no./ Type	TDS 3K0.01S-A	TDS 5K0.05S-A	TDS 8K0.05-A
Readability (d)	0.01 g	0.05 g	0.05 g
Weighing range (max)	3 kg	5 kg	8 kg
Reproducibility	0.02 g	0.05 g	0.05 g
Linearity	±0.05 g	±0.15 g	± 0.15 g
Smallest part weight for piece counting - under lab conditions*	10 mg	10 mg	50 mg
Smallest part weight for piece counting - under normal conditions**	100 mg	100 mg	500 mg
Adjustment points	1/2/3 kg	1/2/5 kg	2/5/8 kg
Recommended adjustment weight (not supplied)	3 kg (F1)	5 kg (F1)	8 kg (F1)
Stabilization time (typical)	3 sec.		
Warm-up time	120 min		
Weighing Units	kg, g, gn, dwt, tl (Tw), tl (HK), ozt, tl (Singap, Malays), ct, mo, lb, oz		
Humidity of air	max. 80% rel. (non-condensing)		
Allowable ambient temperature	10 °C ... + 40 °C		
Input voltage Appliance	6V, 1A		
Input voltage Mains adapter	100 V - 240 V AC, 50/60 Hz		
Rechargeable battery operation (optional)	Operating period 48 h (background illumination OFF) Operating period 24 h (background illumination ON) Loading time approx. 8 hrs.		
Auto off (rechargeable battery)	selectable off, 30s, 1, 2, 5, 30, 60 min		
Dimensions housing (W x D x H) [mm]	225 x 115 x 60		
Weighing pan	228 x 228 x 95mm Metal, lacquered	228 x 228 x 95mm Metal, lacquered	308 x 318 x 75 mm Metal, lacquered
Net weight (kg)	4.1	4.1	7.5
Interfaces	RS-232 (optional), USB device (optional) via KUP		
Underfloor weighing device	no		yes (hook optional)

KERN	DS 10K0.1S	DS 16K0.1	DS 20K0.1
Item no./ Type	TDS 10K0.1S-A	TDS 16K0.1-A	TDS 20K0.1-A
Readability (d)	0.1 g	0.1 g	0.1 g
Weighing range (max)	10 kg	16 kg	20 kg
Reproducibility	0.1 g	0.1 g	0.1 g
Linearity	±0.3 g	± 0.3 g	±0.3 g
Smallest part weight for piece counting - under lab conditions*	100 mg	100 mg	100 mg
Smallest part weight for piece counting - under normal conditions**	1 g	1 g	1 g
Adjustment points	2/5/10 kg	5/10/15 kg	5/10/20 kg
Recommended adjustment weight (not supplied)	10 kg (F1)	15 kg (F1)	20 kg (F1)
Warm-up time	120 min	120 min	120 min
Stabilization time (typical)	3 sec.		
Weighing Units	kg, g, gn, dwt, tl (Tw), tl (HK), ozt, tl (Singap, Malays), ct, mo, lb, oz		
Humidity of air	max. 80% rel. (non-condensing)		
Allowable ambient temperature	10 °C ... + 40 °C		
Input voltage Appliance	6V, 1A		
Input voltage Mains adapter	100 V - 240 V AC, 50/60 Hz		
Rechargeable battery operation (optional)	Operating period 48 h (background illumination OFF) Operating period 24 h (background illumination ON) Loading time approx. 8 hrs.		
Auto-Off (rechargeable battery)	selectable off, 30s, 1, 2, 5, 30, 60 min		
Dimensions caisse (l x L x h) [mm]	225 x 115 x 60		
Weighing plate [mm]	228 x 228 x 95 mm Metal, lacquered	308x318x75 Metal, lacquered	
Net weight (kg)	4.1	7.5	
Interfaces	RS-232 (optional), USB device (optional) via KUP		
Underfloor weighing device	no	yes (hook optional)	

KERN	DS 30K0.1	DS 30K0.1L	DS 36K0.2	DS 36K0.2L
Item no./ Type	TDS 30K0.1-A	TDS 30K0.1L-A	TDS 36K0.2-A	TDS 36K0.2L-A
Readability (d)	0.1 g	0.1 g	0.2 g	0.2 g
Weighing range (max)	30 kg	30 kg	36 kg	36 kg
Reproducibility	0.2 g	0.2 g	0.2 g	0.2 g
Linearity	±0.5 g	±0.5 g	± 0.6 g	± 0.6 g
Smallest part weight for piece counting - under lab conditions*	100 mg	100 mg	100 mg	100 mg
Smallest part weight for piece counting - under normal conditions**	1 g	1 g	1 g	1 g
Adjustment points	10/20/30 kg	10/20/30 kg	10/20/35 kg	10/20/35 kg
Recommended adjustment weight (not supplied)	30 kg (E2)	30 kg (E2)	35 kg (F1)	35 kg (F1)
Warm-up time	120 min	120 min	120 min	120 min
Stabilization time (typical)	3 sec.			
Weighing Units	kg, g, gn, dwt, tl (Tw), tl (HK), ozt, tl (Singap, Malays), ct, mo, lb, oz			
Humidity of air	max. 80% rel. (non-condensing)			
Allowable ambient temperature	10 °C ... + 40 °C			
Input voltage Appliance	6V, 1A			
Input voltage Mains adapter	100 V - 240 V AC, 50 Hz			
Rechargeable battery operation (optional)	Operating period 48 h (background illumination OFF) Operating period 24 h (background illumination ON) Loading time approx. 8 hrs.			
Auto-Off (rechargeable battery)	selectable off, 30s, 1, 2, 5, 30, 60 min			
Dimensions caisse (l x L x h) [mm]	225 x 115 x 60			
Weighing plate [mm]	308 x 318 x 75 Metal, lacquered	500 x 400 x 125 Metal, lacquered	308 x 318 x 75 Metal, lacquered	500 x 400 x 125 Metal, lacquered
Net weight (kg)	7.5	9.5	7.5	9.5
Interfaces	RS-232 (optional), USB device (optional) via KUP			
Underfloor weighing device	yes (hook optional)	no	yes (hook optional)	no

KERN	DS 60K0.2	DS 65K0.5	DS 100K0.5
Item no./ Type	TDS 60K0.2-A	TDS 65K0.5-A	TDS 100K0.5-A
Readability (d)	0.2 g	0.2 g	0.5 g
Weighing range (max)	60 kg	60 kg	100 kg
Reproducibility	0.4 g	0.5 g	0.5 g
Linearity	±1 g	±1.5 g	± 1.5 g
Smallest part weight for piece counting - under lab conditions*	200 mg	200 mg	500 mg
Smallest part weight for piece counting - under normal conditions**	2 g	2 g	5 g
Adjustment points	20/40/60 kg	20/40/60 kg	20/50/100 kg
Recommended adjustment weight (not supplied)	60 kg (F1)	60 kg (F1)	50 kg (F1) + 50 kg (F1)
Warm-up time	120 min	120 min	120 min
Stabilization time (typical)	3 sec.		
Weighing Units	kg, g, gn, dwt, tl (Tw), tl (HK), ozt, tl (Singap, Malays), ct, mo, lb, oz		
Humidity of air	max. 80% rel. (non-condensing)		
Allowable ambient temperature	10 °C ... + 40 °C		
Input voltage Appliance	6V, 1A		
Input voltage Mains adapter	100 V - 240 V AC, 50 Hz		
Rechargeable battery operation (optional)	Operating period 48 h (background illumination OFF) Operating period 24 h (background illumination ON) Loading time approx. 8 hrs.		
Auto-Off (rechargeable battery)	selectable off, 30s, 1, 2, 5, 30, 60 min		
Dimensions caisse (l x L x h) [mm]	225 x 115 x 60		
Weighing plate [mm]	500 x 400 x 125 Metal, lacquered		
Net weight (kg)	9,5		
Interfaces	RS-232 (optional), USB device (optional) via KUP		

KERN	DS 150K1
Item no./ Type	TDS 150K1-A
Readability (d)	1 g
Weighing range (max)	150 kg
Reproducibility	1 g
Linearity	±3 g
Smallest part weight for piece counting - under lab conditions*	1 g
Smallest part weight for piece counting - under normal conditions**	10 g
Adjustment points	50/100/150 kg
Recommended adjustment weight (not supplied)	150 kg (F1)
Warm-up time	120 min
Stabilization time (typical)	3 sec.
Weighing Units	kg, g, gn, dwt, tl (Tw), tl (HK), ozt, tl (Singap, Malays), ct, mo, lb, oz
Humidity of air	max. 80% rel. (non-condensing)
Allowable ambient temperature	10 °C ... + 40 °C
Input voltage Appliance	6V, 1A
Input voltage Mains adapter	100 V - 240 V AC, 50 Hz
Storage battery operation (optional)	Operating period 48 h (background illumination OFF) Operating period 24 h (background illumination ON) Loading time approx. 8 hrs.
Auto-Off (rechargeable battery)	selectable off, 30s, 1, 2, 5, 30, 60 min
Dimensions caisse (l x L x h) [mm]	225 x 115 x 60
Weighing plate [mm]	500 x 400 x 125 Metal, lacquered
Net weight (kg)	9,5
Interfaces	RS-232 (optional), USB device (optional) via KUP

*** Smallest component weight for part counting - under lab conditions:**

- There are ideal ambient conditions for high-resolution counting
- The parts to be counted are not scattered

**** Smallest component part for part counting – under normal conditions:**

- There are unsteady ambient conditions (draft, vibrations)
- The parts to be counted are being scattered

2 Declaration of conformity

The current EC/EU Conformity declaration can be found online in:

www.kern-sohn.com/ce

3 Appliance overview

3.1 Components





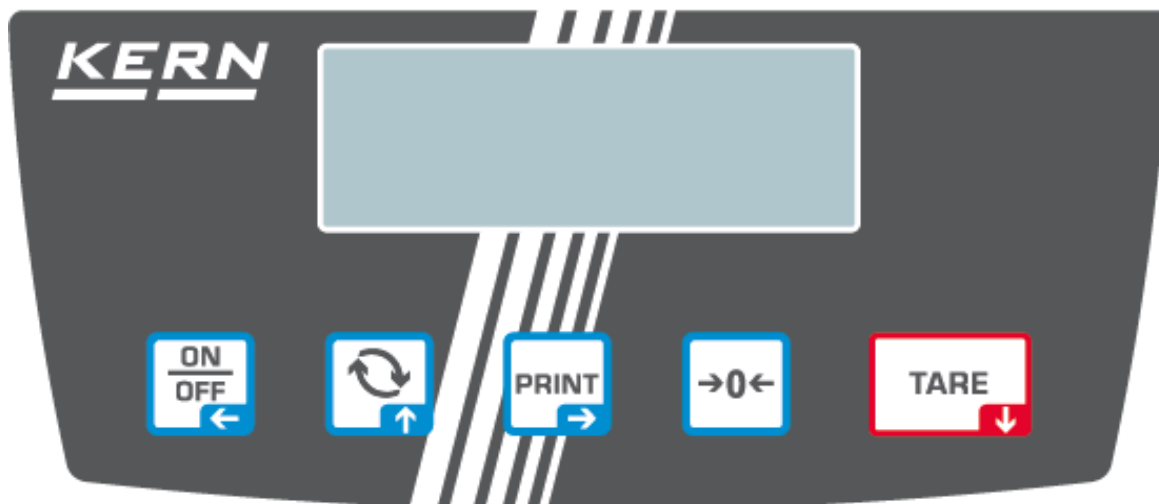

Pos.	Designation	Pos	Designation
1	Weighing plate	5	Keypad
2	Connection power adapter	6	Battery case
3	KUP-connection (KERN Universal Port)	7	Level indicator (position depends on model)
4	Display	8	foot screws



3.2 Operating elements



3.2.1 Keyboard overview





Button	Name	Function in Operating mode	Function in Menu
	ON/OFF-button	<ul style="list-style-type: none"> ➤ Turn on/off ➤ Background illumination of the display on/off 	<ul style="list-style-type: none"> ➤ Navigation key ← ➤ Menu level back ➤ Exit menu / back to weighing mode.
	↻-key	<ul style="list-style-type: none"> ➤ Quick change button, see chap. 10.3 	<ul style="list-style-type: none"> ➤ Navigation key ↑ ➤ Select menu item
	PRINT button	<ul style="list-style-type: none"> ➤ Calculate weighing data via interface 	<ul style="list-style-type: none"> ➤ Navigation key → ➤ Activate menu item ➤ Confirm selection
	ZERO key	<ul style="list-style-type: none"> ➤ Zeroing (Zeroing range 2% maximum) 	
	TARE-button	<ul style="list-style-type: none"> ➤ Taring 	<ul style="list-style-type: none"> ➤ Invoke application menu (press button long time) ➤ Navigation key ↓ ➤ Select menu item

3.2.2 Numeric entry

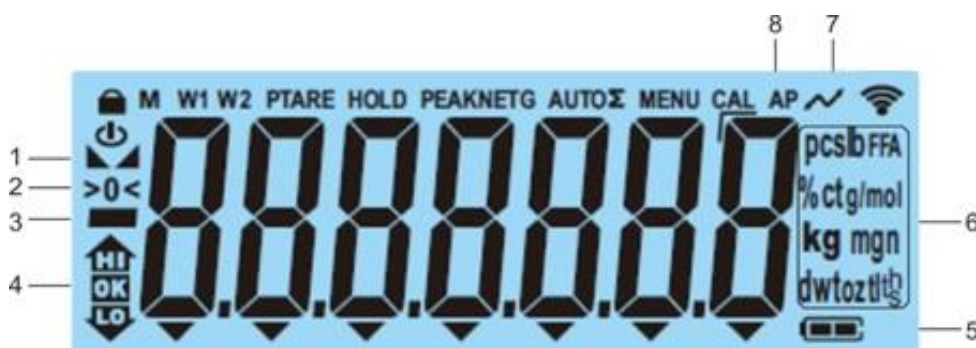
Button	Designation	Function
	Navigation key →	Select cipher Confirm entry. Press button repeatedly for every digit. Wait until the numeric input window extinguishes.
	Navigation key ↓	Reduce flashing cipher (0 – 9)
	Navigation key ↑	Increase flashing cipher (0 – 9)

3.2.3 Overview of displays



Position	Display	Description
1		Stability display
2	>0<	Zero display
3	—	Minus display
4		Tolerance marks for check weighing
5		Rechargeable battery charge indicator
6	Units display / Pcs/ %	selectable g, kg, lb, gn, dwt, oz, ozt or Application icon [Pcs] for piece counting or [%] for determination of percentage
7		Data transfer running
8	AP	Autoprint enabled
-	G	Display gross weight value
-	NET	Display net weight value
-	Σ	Weighing data can be found in the sum memory

4 Basic Information (General)

4.1 Proper use

The balance you purchased is intended to determine the weighing value of material to be weighed. It is intended to be used as a “non-automatic balance”, i.e. the material to be weighed is manually and carefully placed in the centre of the weighing pan. As soon as a stable weighing value is reached, the weighing value can be read.

4.2 Improper Use

Our balances are non-automatic balances and not provided for use in dynamic weighing processes. However, the balances can also be used for dynamic weighing processes after verifying their individual operative range, and here especially the accuracy requirements of the application.

Do not leave permanent load on the weighing pan. This may damage the measuring system.

Impacts and overloading exceeding the stated maximum load (max) of the balance, minus a possibly existing tare load, must be strictly avoided. Balance may be damaged by this.

Never operate the balance in explosive environment. The serial version is not explosion protected.

The structure of the balance may not be modified. This may lead to incorrect weighing results, safety-related faults and destruction of the balance.

The balance may only be used according to the described conditions. Other areas of use must be released by KERN in writing.

4.3 Warranty

Warranty claims shall be voided in case:

- Our conditions in the operation manual are ignored
- The appliance is used beyond the described uses
- The appliance is modified or opened
- Mechanical damage and damage by media, liquids, natural wear and tear
- The appliance is improperly set up or incorrectly electrically connected
- The measuring system is overloaded

4.4 Monitoring of Test Resources

In the framework of quality assurance the measuring-related properties of the balance and, if applicable, the testing weight, must be checked regularly. The responsible user must define a suitable interval as well as type and scope of this test. Information is available on KERN's home page (www.kern-sohn.com) with regard to the monitoring of balance test substances and the test weights required for this. In KERN's accredited DKD calibration laboratory test weights and balances may be calibrated (return to the national standard) fast and at moderate cost.

5 Basic Safety Precautions

5.1 Pay attention to the instructions in the Operation Manual



⇒ Carefully read this operation manual before setup and commissioning, even if you are already familiar with KERN balances.

5.2 Personnel training

The appliance may only be operated and maintained by trained staff.

6 Transport and storage

6.1 Testing upon acceptance

When receiving the appliance, please check packaging immediately, and the appliance itself when unpacking for possible visible damage.

6.2 Packaging / return transport



- ⇒ Keep all parts of the original packaging for a possibly required return.
- ⇒ Only use original packaging for returning.
- ⇒ Prior to dispatch disconnect all cables and remove loose/mobile parts.
- ⇒ Reattach possibly supplied transport securing devices.
- ⇒ Secure all parts such as the wind screen, the weighing platform, power unit etc. against shifting and damage.

7 Unpacking, Installation and Commissioning

7.1 Installation Site, Location of Use

The balances are designed in a way that reliable weighing results are achieved in common conditions of use.

You will work accurately and fast, if you select the right location for your balance.

Therefore, observe the following for the installation site:

- Place the balance on a firm, level surface.
- Avoid extreme heat as well as temperature fluctuation caused by installing next to a radiator or in the direct sunlight.
- Protect the balance against direct draughts due to open windows and doors.
- Avoid jarring during weighing.
- Protect the balance against high humidity, vapours and dust.
- Do not expose the device to extreme dampness for longer periods of time. Non-permitted condensation (condensation of air humidity on the appliance) may occur if a cold appliance is taken to a considerably warmer environment. In this case, acclimatize the disconnected appliance for ca. 2 hours at room temperature.
- Avoid static charge of goods to be weighed or weighing container.
- Do not operate in areas with hazard of explosive material or in potentially explosive atmospheres due to materials such as gasses, steams, mists or dusts.
- Keep away chemicals (such as liquids or gasses), which could attack and damage the balance inside or from outside.
- Keep IP protection of the device.
- In the event of the occurrence of electromagnetic fields, static charges (e.g., when weighing / counting plastic parts) and unstable power supply, large display deviations (incorrect weighing results, as well as damage to the scale) are possible. In that case, the location must be changed.

7.2 Unpacking and checking

Remove device and accessories from packaging, remove packaging material and install the device at the planned work place. Check if that there has been no damage and that all items of delivery scope are present.

Scope of delivery / serial accessories:

- Balance, see chap. 3.1
- Mains adapter
- Operating instructions
- Protective hood

7.3 Assembling, Installation and Levelling

- ⇒ Remove the transport lock on the underside of the scale.
- ⇒ Install weighing plate and wind shield if necessary.
- ⇒ Ensure that the balance is installed in a level position.
- ⇒ Level balance with foot screws until the air bubble of the water balance is in the prescribed circle.

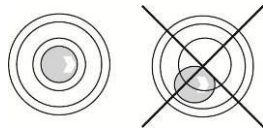

- ⇒ Check levelling regularly

7.4 Mains connection



Select a country-specific power plug and insert it in the mains adapter.



Check, whether the voltage acceptance on the scales is set correctly. Do not connect the scales to the power mains unless the information on the scales (sticker) matches the local mains voltage.



Only use KERN original mains adapter. Using other makes requires consent by KERN.



Important:

- Before starting your weighing balance, check the mains cable for damage.
- Ensure that the power unit does not come into contact with liquids.
- Ensure access to mains plug at all times.

7.5 Rechargeable battery operation (optional)

<p>ATTENTION</p>  	<ul style="list-style-type: none">⇒ The rechargeable battery and the battery match with each other. Only use the delivered mains adapter.⇒ Do not use the balance during the loading process.⇒ The rechargeable can only be replaced by the same or by a type recommended by the manufacturer.⇒ The rechargeable battery is not protected against all environmental influences. If the rechargeable battery is exposed to certain environmental influences, it may set on fire or explode. Persons may be injured or material damage may occur.⇒ Protect the rechargeable battery against fire and heat.⇒ Do not bring the rechargeable battery in contact with fluids, chemical substances or salt.⇒ Do not expose the rechargeable battery to high pressure or microwaves.⇒ Under no circumstances the rechargeable batteries and the charging unit may be modified or manipulated.⇒ Do not use a defective, damaged or deformed rechargeable battery.⇒ Do not connect or short-circuit the electrical contacts of the rechargeable battery with metallic objects.⇒ Liquid may squirt out from a damaged rechargeable battery. If the liquid gets into contact with the skin or the eyes, the skin and the eyes may be irritated.⇒ Ensure the correct polarity when inserting or changing the rechargeable battery (see instructions in the battery compartment)⇒ The rechargeable battery operation is overridden when the mains adapter is connected. For weighing in mains operation > 48 hrs. the rechargeable batteries must be removed! (Danger of overheating).⇒ If the rechargeable battery starts to smell, being hot, changing the colour or being deformed, it must be immediately unplugged from mains supply and from the balance if possible.
--	---

7.5.1 Load rechargeable battery

The rechargeable battery pack (Option) is charged using the mains cable supplied.

Before the first use, the rechargeable battery package should be charged by connecting it to the mains power cable for at least 15 hours.

To save the rechargeable battery, in menu (see chap.13.3.1.) the automatic switch-off function < **AutoFF** > can be activated.

If the capacity of the rechargeable batteries is exhausted, < **LoBat** > appears in the display. Connect the power cable as soon as possible to load the rechargeable battery. Charging time until complete recharging is approx. 8 h.

7.6 Connection of peripheral devices

Before connecting or disconnecting of additional devices (printer, PC) to the data interface, always disconnect the balance from the power supply.

With your balance, only use accessories and peripheral devices by KERN, as they are ideally tuned to your balance.

7.7 Initial Commissioning

In order to obtain exact results with the electronic balances, your balance must have reached the operating temperature (see warming up time chap. 1). During this warming up time the balance must be connected to the power supply (mains, rechargeable accumulator or battery).

The accuracy of the balance depends on the local acceleration of gravity.

Strictly observe hints in chapter Adjustment.

7.8 Adjustment

As the acceleration value due to gravity is not the same at every location on earth, each display unit with connected weighing plate must be coordinated - in compliance with the underlying physical weighing principle - to the existing acceleration due to gravity at its place of location (only if the weighing system has not already been adjusted to the location in the factory). This adjustment process must be carried out for the first commissioning, after each change of location as well as in case of fluctuating environment temperature. To receive accurate measuring values it is also recommended to adjust the display unit periodically in weighing operation.

- i** • Arrange the required adjustment weight, see chap. 1.
Carry out adjustment as near as possible to the highest load of the balance (recommended adjustment weight see chap. 1). Weights of different nominal values or tolerance classes may be used for adjustment but are not optimal for technical measuring. The accuracy of the adjustment weight must correspond approximately to or, if possible, be better than, the readability [**d**] of the balance. Info about test weights can be found on the Internet at: <http://www.kern-sohn.com>
- Observe stable environmental conditions. A warm up time (see chapter 1) is required for stabilization.
- Ensure that there are no objects on the weighing pan.

7.8.1 External adjustment < cALeHt >

⇒ Press and hold the TARE and ON/OFF buttons simultaneously to enter the setup menu.

⇒ Wait until the first menu item < cAL > is displayed.

⇒ Confirm by → button, < cALeHt > will be displayed.

⇒ Confirm by pressing the → button, the first selectable adjustment weight is displayed.

⇒ Use the navigation keys ↓↑ to select the desired adjustment weight, see chap. 1 „Adjustment points“ or „Recommended adjustment weight“ Numerical input, see chap. 3.2.2

⇒ Prepare the required adjustment weight.

⇒ Acknowledge selection by → button. < Zero >, < PutLd > followed by the weight value of the adjustment weight to be placed will be displayed.

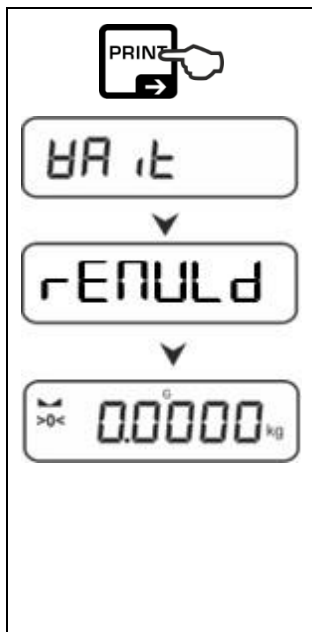

⇒ Place the adjustment weight and confirm with →-button, < AR it > followed by < rENULd > will be displayed.

⇒ Once < rENULd > is displayed, remove the adjustment weight.

⇒ After successful adjustment the balance automatically returns to weighing mode.
In case of an adjustment error (e.g. objects on the weighing plate) the display will show the error message < Erorn >. Switch off balance and repeat the adjustment process.

7.8.2 External adjustment with user-defined adjustment weight < cAL Eud >

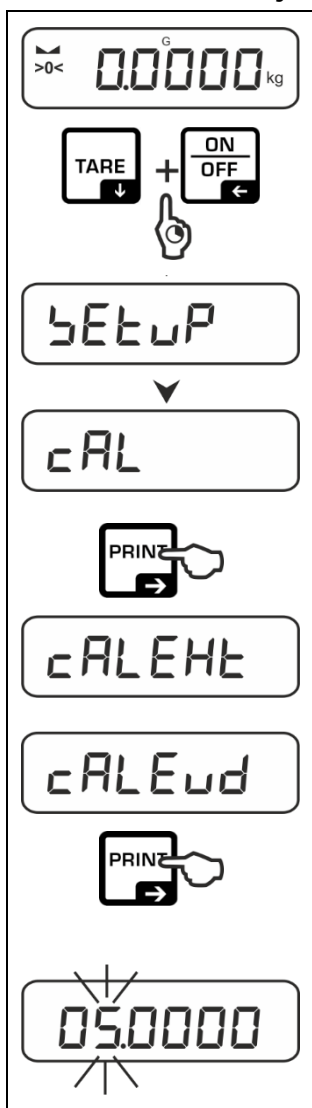

⇒ Press and hold the TARE and ON/OFF buttons simultaneously to enter the setup menu.

⇒ Wait until the first menu item < CAL > is displayed.

⇒ Confirm by → button, < CAL Eud > will be displayed.

⇒ Use the navigation keys to select ↓ ↑ < CAL Eud >.

⇒ Acknowledge by → button. The numeric input window for the weight value of the adjustment weight appears. The active digit is flashing.

⇒ Provide adjustment weight.

⇒ Enter weight value, numeric input see chap. 3.2.2

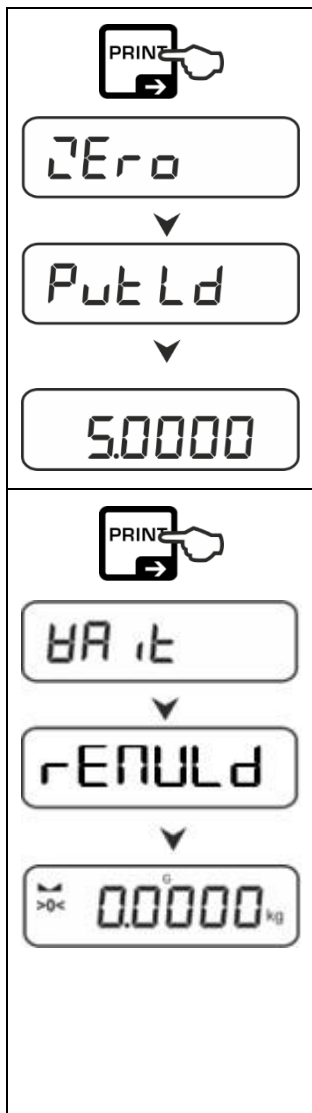

⇒ Acknowledge selection by → button. <Zero>, <Put Ld> followed by the weight value of the adjustment weight to be placed will be displayed.

⇒ Place the adjustment weight and confirm with → button, <Put Ld> followed by <Zero> will be displayed.

⇒ Once <Zero> is displayed, remove the adjustment weight.

⇒ After successful adjustment the balance automatically returns to weighing mode.
In case of an adjustment error (e.g. objects on the weighing plate) the display will show the error message <Error>. Switch off balance and repeat the adjustment process.

7.8.3 Gravitational constant adjustment location < GrAADJ >

⇒ Press and hold the TARE and ON/OFF buttons simultaneously to enter the setup menu.

⇒ Wait until the first menu item < CAL > is displayed.

⇒ Confirm by → button, < CALHEt > will be displayed.

⇒ Use the navigation keys to select ↓ ↑ < GrAADJ >.

⇒ Acknowledge using → button, the current setting is displayed. The active digit is flashing.

⇒ Enter weight value and confirm using the → button, numeric entry see chap. 3.2.2. Weighing balance returns to menu.

⇒ Press repeatedly ←-button to exit menu.

7.8.4 Gravitational constant adjustment location < GrAuSE >

⇒ Press and hold the TARE and ON/OFF buttons simultaneously to enter the setup menu.

⇒ Wait until the first menu item < cAL > is displayed.

⇒ Confirm by → button, < cALEHt > will be displayed.

⇒ Use the navigation keys to select ↓ ↑ < GrAuSE >.

⇒ Acknowledge using → button, the current setting is displayed. The active digit is flashing.-+

⇒ Enter weight value and confirm using the → button, numeric entry see chap. 3.2.2. Weighing balance returns to menu.

⇒ Press repeatedly ←-button to exit menu.

8 Basic Operation

8.1 Turn on/off

Start-up:

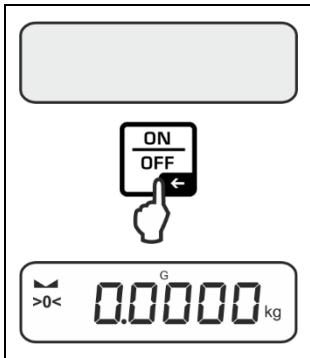

- ⇒ Press the **ON/OFF** button.
The display lights up and the balance carries out a selftest.
Wait until the weight display appears.
The scales are now ready to weigh using the last active application

Switching off:

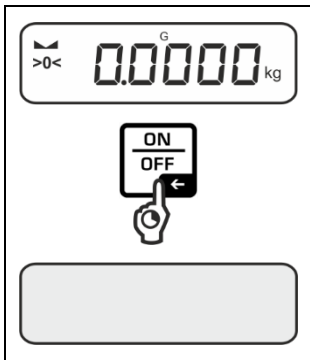

- ⇒ Keep **ON/OFF** button pressed until the display disappears

8.2 Simple weighing



- ⇒ Check zero display [**>0<**] and set to zero with the help of the **ZERO** key, as required.
- ⇒ Place goods to be weighed on balance
- ⇒ Wait until the stability display appears (▣).
- ⇒ Read weighing result.



Overload warning

Overloading exceeding the stated maximum load (max) of the device, minus a possibly existing tare load, must be strictly avoided.

This could damage the instrument.

Exceeding the maximum load is indicated by the display “**f - - ?**”. Unload balance or reduce preload.

8.3 Zeroing

In order to obtain optimal weighing results, reset to zero the balance before weighing. Zeroing is only possible in the range $\pm 2\%$ Max.

For values greater than $\pm 2\%$ maximum the error message $\langle \text{OL} \text{ } \text{HI} \text{ } \text{LE} \rangle$ is displayed

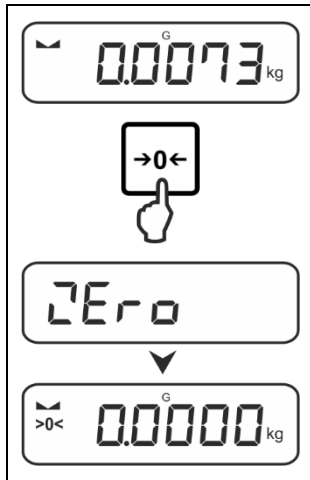

- ⇒ Unload the balance
- ⇒ Press the **ZERO** key to set the balance to zero.

8.4 Taring

The dead weight of any weighing container may be tared away by pressing a button, so that the following weighing procedures show the net weight of the goods to be weighed.

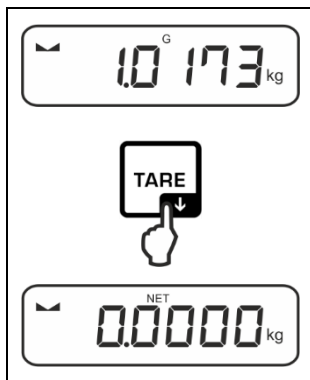



- ⇒ Put weighing container on the weighing pan.
- ⇒ Wait until the stability display appears (▲▼), then press **TARE** key. The weight of the container is now internally saved. Zero display and indicator $\langle \text{NET} \rangle$ will appear. $\langle \text{NET} \rangle$ informs that all shown weight values are net values.

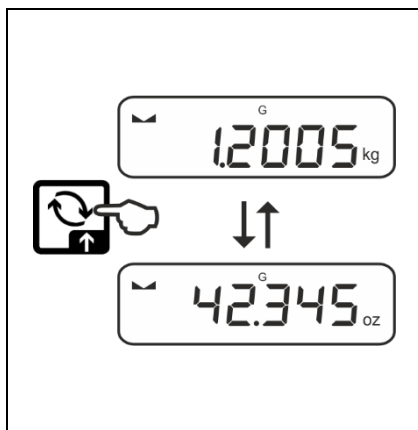

- When the balance is unloaded the saved taring value is displayed with negative sign.
- To delete the stored tare value, unload the weighing plate and press the **TARE** key or the **ZERO** key.
- The taring process can be repeated any number of times, e.g. when adding several components for a mixture (adding). The limit is reached when the taring range capacity is full.
- Numerical input of tare (PRE-TARE)

8.5 Switch-over weighing unit



⇒ Using  button, it is possible to switch over between the enabled unit 1 and unit 2. (To activate the unit, see chap. 10.3.1.)

i When switching-on the balance, the unit in which the balance has been switched off, will be displayed.

8.6 Under-floor weighing (optional, varies by model)

Objects unsuitable for placing on the weighing scale due to size or shape may be weighed with the help of the flush-mounted platform.

Proceed as follows:

- ⇒ Switch off the balance.
- ⇒ Remove weighing plate
- ⇒ Place weighing plate with mounted stirrup & hook (optional item).
- ⇒ Hook-on the material to be weighed and carry out weighing.



CAUTION

- **Always ensure that all suspended objects are stable enough to hold the desired goods to be weighed safely (danger of breaking).**
- **Never suspend loads that exceed the stated maximum load (max) (danger of breaking)**

Always ensure that there are no persons, animals or objects that might be damaged underneath the load.



NOTICE

After completing the underfloor weighing the opening on the bottom of the balance must always be closed (dust protection).

9 Operating concept

From factory the balance is delivered with various applications (normal weighing, check weighing, counting). After the first start-up the balance is in the <Weighing> application.

In the **application menu** (see chap.13.2.) however, you can define, selecting an application, in which mode the balance after switching-on has to continue working. Either as per standard in weighing mode or e.g. as check balance or counting balance

Selecting an application:

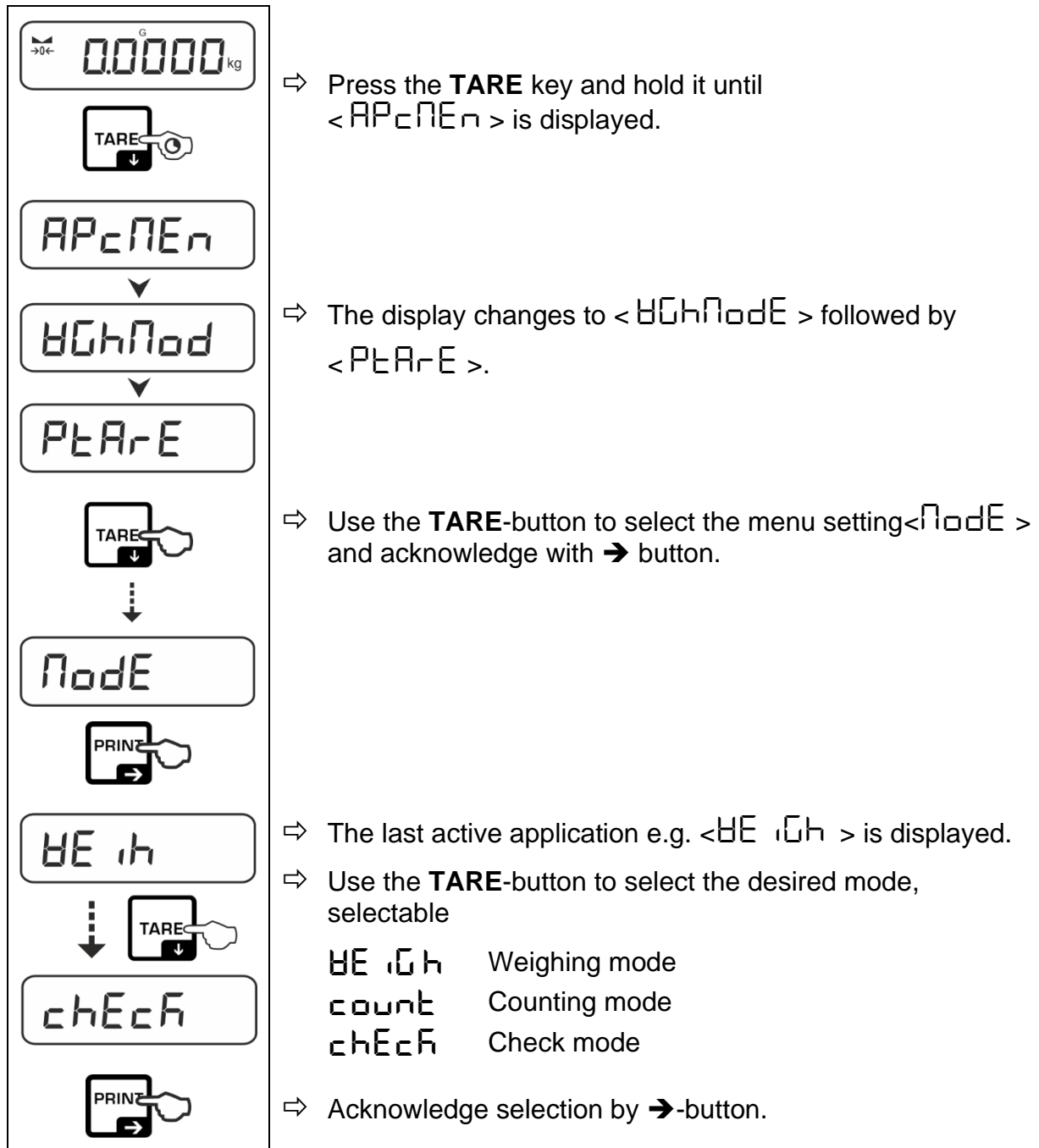

According to the selected application in the application menu just appear the application-specific settings, so that you reach the target quickly without deviation.



- Information about the application-specific settings you will find in the description of the respective application.
- All basic settings and parameters, which influence the whole operation of the balance, are resumed in the **Setup Menu** (see chap.13.3.). These settings remain valid for all applications.
- The number of the available applications depends on the model.

Change application:

- ⇒ Press the **TARE** button and keep it pressed until the first menu item of the setup menu will be displayed
- ⇒ Use the **TARE**-button to select the menu setting **< Mode >** and acknowledge with **→** button. The current setting will be displayed.
- ⇒ Use the **TARE**-button to select the desired mode and acknowledge with **→** button.

10 Application <Weighing>

How to carry out a simple weighing and taring, please refer to chap. 8.2 or 8.4. Further specific settings you will find in the following chapters.

- i** Shouldn't the application <Weighing> already be enabled, select the menu setting <MODE → WEIGH>, see chap. 9

10.1 Application-specific settings

Call up menu:

- ⇒ Press the **TARE** key and hold it until <APCNER> is displayed.
- ⇒ The display changes to <WEIGH> followed by <PRE-TARE>.
- ⇒ Navigation in menu see chap. 13.1

Overview:

Level 1	Level 2	Level 3	Description / Chapter
PRE-TARE PRE-TARE	ACTUAL		Take over the placed weight as PRE-TARE value, see chap. 10.2.1
	NUMERICAL		Numerical input of the tare weight, see chap. 10.2.2.
	CLEAR		Delete PRE-TARE value
hold	-		Start-Hold function, see chap. 10.2.3
unit Units	available weighing units, see chap. 1		This function defines in which weighing unit the result will be displayed.
	FFA		Multiplication factor see chap. 10.2.5
	Pcs		Application unit counting
	%		Application unit for determining percentages see chap. 10.2.4
	mol		Mol weighing mode, see chap. 10.2.6
MODE Application mode	WEIGH	Weighing mode	see chap. 9.
	COUNT	Counting mode	
	CHECK	Check mode	

10.2 Description of individual functions



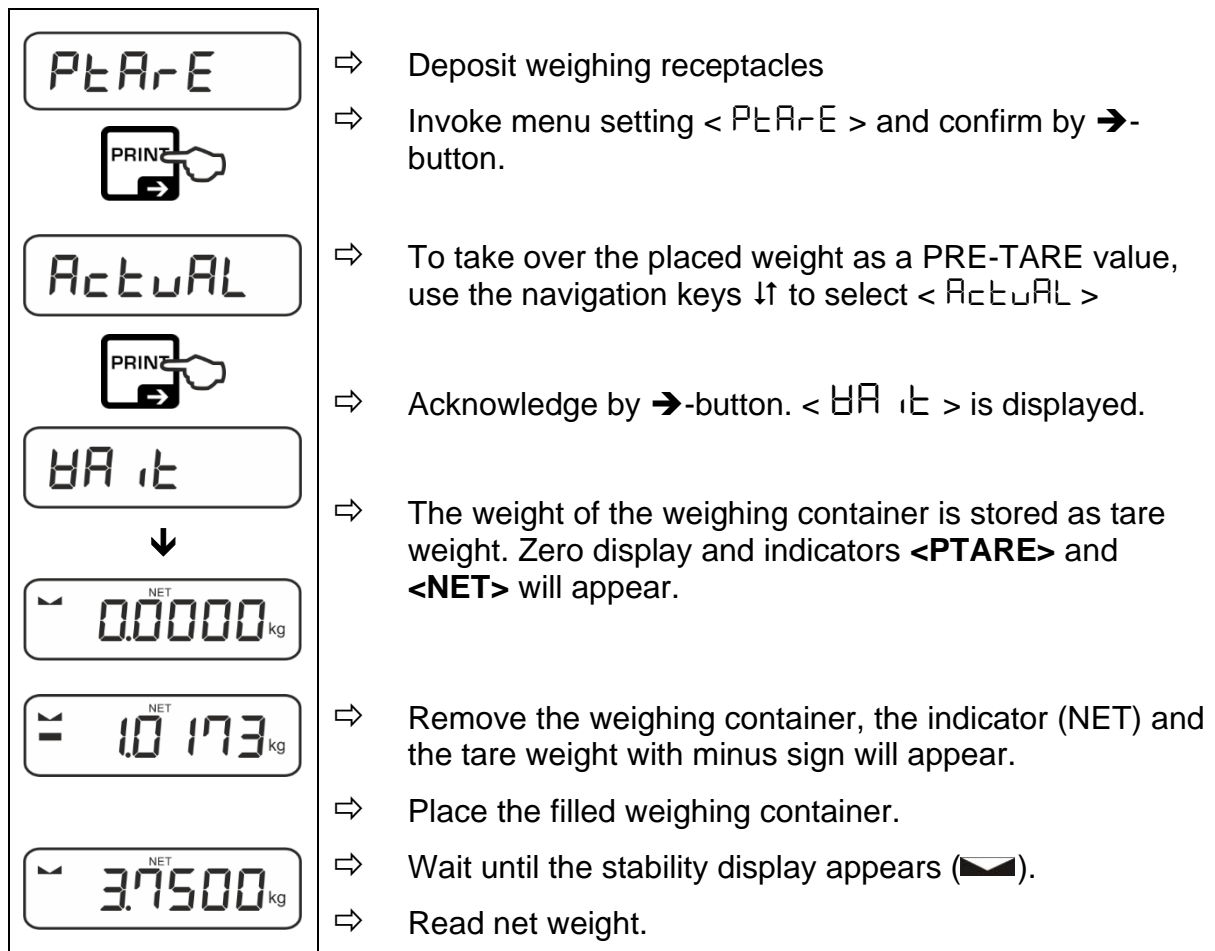

10.2.1 Take over the placed weight as PRE-TARE value

< PRETARE → ACTUAL >







i The entered tare weight remains invalid until a new tare weight is input. To delete press the TARE key or confirm the menu setting <CLEAR> using the → button.

10.2.2 Enter the known tare weight numerically < PTARE → NANUAL >

	⇒ Invoke menu setting < P <small>T</small> A <small>R</small> E > and confirm by →-button.
	⇒ Use the navigation keys ↓↑ to select the setting < N <small>A</small> N <small>U</small> A <small>L</small> > and confirm with → button.
	⇒ Enter known tare weight, numerical input see chap. 3.2.2, the active digit flashes.
↓	
	⇒ The input weight is saved as tare weight, the indicators < P <small>T</small> A <small>R</small> E > and < N <small>E</small> T > and the tare weight with minus sign will appear.
	⇒ Place the filled weighing container.
	⇒ Wait until the stability display appears (▢).
	⇒ Read net weight.



i The entered tare weight remains invalid until a new tare weight is input. To delete enter the zero value or confirm the menu setting < CLEAR > using the →-button.

10.2.3 Data-Hold function < hOLD >

	⇒ Menu setting < h <small>O</small> L <small>D</small> >
	⇒ Place goods to be weighed.
	⇒ Acknowledge by →-button.
	⇒ The first stable weight value is symbolised by [HOLD] in the upper edge of the display. After the load is removed, the value is left in the display for another 10 seconds.
	⇒ If no stable value could be determined after 15 secs, an average value is displayed.

10.2.4 Percent weighing

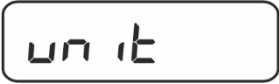
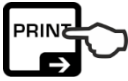
The application **<Percent weighing>** allows to check the weight of a sample in percent, based on a reference weight.

	⇒ Select menu setting < unit > .
	⇒ Put a reference weight which corresponds to 100 %.
<div style="display: flex; justify-content: space-between; align-items: center;"> % </div>	⇒ Acknowledge by → -button.
	⇒ Use the navigation keys ↓ to select the setting < % > and confirm on → button.
<div style="display: flex; justify-content: center; align-items: center;"> <div style="border: 1px solid black; padding: 5px; margin-bottom: 5px;"> unit </div> <div style="margin: 0 5px;">↓</div> <div style="border: 1px solid black; padding: 5px;"> 10.173^{kg} </div> </div>	⇒ Confirm the flashing weight value of the reference weight using → button.
<div style="display: flex; justify-content: space-between; align-items: center;"> ☰ 100.00[%] </div>	⇒ From now on the weight of the sample will be shown in percent based on the reference weight

- i** • Using  button, it is possible to switch over between the enabled unit 1 and unit 2 (enabling the unit).



^G 19.9%

↓↑

^G 0.2170^{kg}

The required settings can also be defined quickly and conveniently by pressing the  button (without calling up the **< unit >** menu), see chap. 10.3.2.

10.2.5 Weighing with multiplication factor

Here you determine with which factor the weighing result (in gram) will be multiplied.

By that way, e.g. a known error factor in the weight determination can be immediately taken into account.

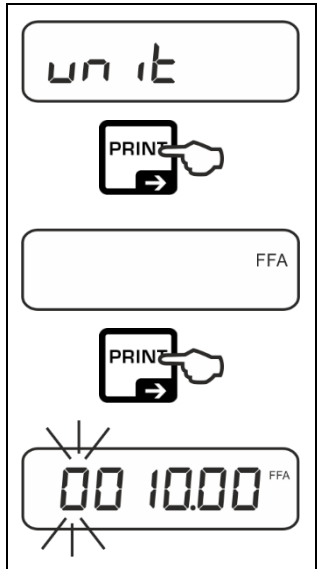

⇒ Select menu setting < unit > and confirm on → button.

⇒ Use the navigation keys ↓↑ to select the setting < FFA > and confirm on → button.

⇒ Enter multiplication factor, numerical input see chap. 3.2.2, the active digit flashes.

i The required settings can also be defined quickly and conveniently by pressing the ↶ key (without calling up the < unit > menu), see chap. 10.3.2.

10.2.6 Molar weighing mode

This function calculates the amount of a substance (in mol) based on the molar mass and the weight of the substance.

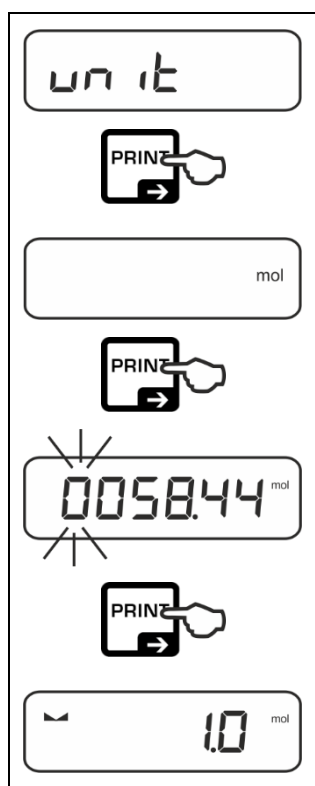

The diagram shows a vertical sequence of five steps for entering molar mass in mol weighing mode:

- Step 1: The display shows the menu setting $\langle \text{mol} \rangle$. An arrow points to the right arrow button on the PRINT key.
- Step 2: The display shows the unit mol . An arrow points to the down arrow navigation key.
- Step 3: The display shows the numerical input 0058.44 mol . The active digit (the decimal point) is flashing. An arrow points to the PRINT key.
- Step 4: The display shows the weight 1.0 mol . An arrow points to the PRINT key.

⇒ Select menu setting $\langle \text{mol} \rangle$ and confirm on \rightarrow button.

⇒ Use the navigation keys \downarrow to select the setting $\langle \text{mol} \rangle$ and confirm on \rightarrow button.

⇒ Enter molar mass of substance, numerical input see chap. 3.2.2, the active digit flashes.

⇒ Preweigh the substance. The weight is displayed in mol.

i The required settings can also be defined quickly and conveniently by pressing the \rightarrow key (without calling up the $\langle \text{mol} \rangle$ menu), see chap. 10.3.2.



10.3 Quick change key -

The quick-change button  can be allocated with a unit where, if needed, it is possible to switch over fast and conveniently into another enabled unit.

10.3.1 Weighing Units

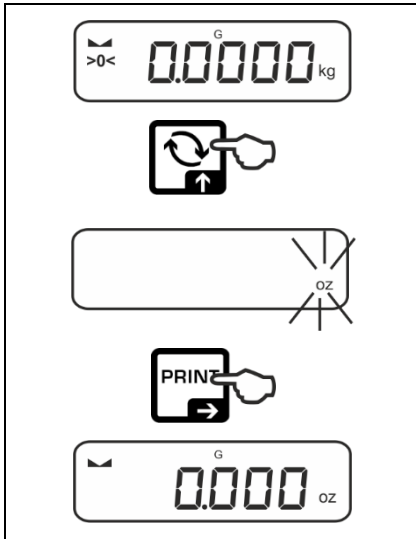
Enable unit:



- ⇒ Press the  key, wait until the display flashes.
- ⇒ Press the  key to select the required unit and confirm by pressing the  key.

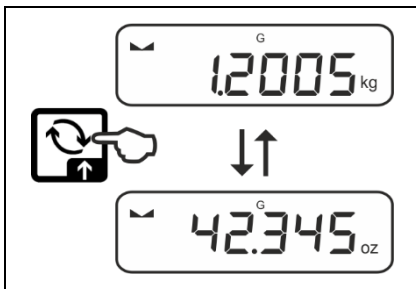

Switch over unit:

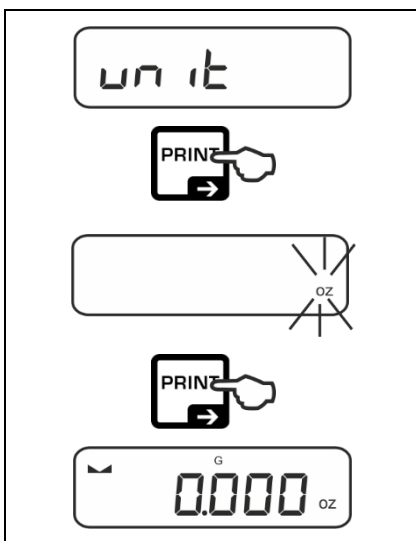

- ⇒ Using  button, it is possible to switch over between the enabled unit 1 and unit 2.

Disable unit:







- ⇒ Select menu setting **< unit >** and confirm on  button.
- ⇒ Wait until the display starts flashing and confirm on  button. From here on, with the  button, all units can be selected anew.

10.3.2 Application units

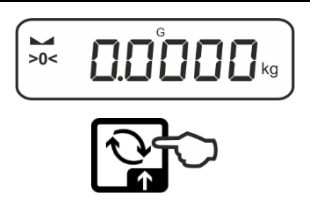
When selecting an application unit (% , Pcs, mol, FFA), the required settings can be selected right after being invoked, using the ↻ button.

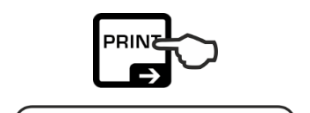
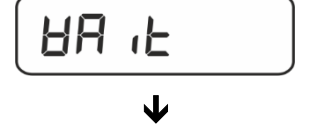
Setting example „Percent weighing“:

	⇒ Press the ↻ key, wait until the display flashes.
	
	⇒ Use ↻ button to select the unit <%>.
	⇒ Put a reference weight which corresponds to 100 %.
	⇒ Acknowledge by →-button.
	
	⇒ Confirm the flashing weight value of the reference weight using → button.
	⇒ From now on the weight of the sample will be shown in percent based on the reference weight.

11 Application <Counting>



Shouldn't the application <Counting> already be enabled, select the menu setting <MODE → count >, see chap. 9

11.1 Application-specific settings

Call up menu:

- ⇒ Press the **TARE** key and hold it until <APCΠEΠ > is displayed.
- ⇒ The display changes to <COUΠOD > followed by <REF >.
- ⇒ Navigation in menu see chap. 13.1

Overview:

Level 1	Level 2	Description / Chapter
REF Reference quantity	5	Reference quantity 5
	10	Reference quantity 10
	20	Reference quantity 20
	50	Reference quantity 50
	FREE	Optional, numeric input, see chap. 3.2.2.
	input	Input piece weight
PRE-TARE PRE-TARE	ACTUAL	Take over the placed weight as PRE-TARE value, see chap. 10.2.1
	NUMAL	Numerical input of the tare weight, see chap. 10.2.2.
	CLEAR	Delete PRE-TARE value
TARGET Check counting,	VALUE	Target value entry
	ERRUPP	Upper tolerance
	ERRLOB	Lower tolerance
	RESET	Reset settings to factory defaults
MODE Application mode	WEIGH	Weighing mode
	COUNT	Counting mode
	CHECK	Check mode
		see chap. 9.

11.2 Using the application

11.2.1 Piece counting

Before the balance can count parts, it must know the average part weight (i.e. reference). Proceed by putting on a certain number of the parts to be counted. The balance determines the total weight and divides it by the number of parts, the so-called reference quantity. Counting is then carried out on the basis of the calculated average piece weight.



- The higher the reference quantity the higher the counting exactness.
- Especially high reference must be selected for small parts or parts with considerably different sizes.
- Smallest counting weight see table „Technical data“.

1. Set reference

Reference quantity 5, 10, 20 or 50

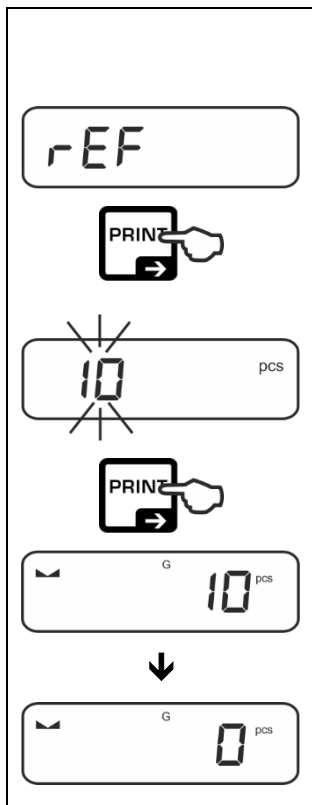

- ⇒ If necessary, put on and tare the weighing container.
- ⇒ Put on the desired quantity of reference pieces.
- ⇒ Invoke menu setting < rEF > and confirm by → button.
- ⇒ Use the navigation keys ↓ to select the reference piece quantity (5, 10, 20, 50) according to the placed reference and confirm with the → button.
- ⇒ The balance will calculate the average item weight and then displays the quantity of pieces.
- ⇒ Remove reference weight. The balance is now in piece counting mode counting all units on the weighing plate.

Reference quantity user-defined:

	⇒ If necessary, put on and tare the weighing container.
	⇒ Put on the desired quantity of reference pieces.
	⇒ Invoke menu setting < rEF > and confirm by → button.
	⇒ Use the navigation keys ↑ to select the setting < FrEE > and confirm on → button.
	⇒ The numeric input window appears.
	⇒ Enter and confirm the quantity of the placed reference parts, numeric input see chap. 3.2.2
	⇒ The balance will calculate the average item weight and then displays the quantity of pieces.
	⇒ Remove reference weight. The balance is now in piece counting mode counting all units on the weighing plate.

2. Parts counting

	⇒ If necessary, put on and tare the weighing container.
	⇒ Fill the counting quantity. The piece quantity is shown directly in the display.

i With the ↻ key you can switch between piece quantity and weight display.

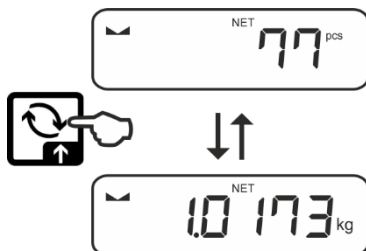



11.2.2 Check counting

The balance allows weighing of goods within set tolerances in keeping with a determined target quantity. With this function one can also check if the weighing good is within a defined tolerance range.

Reaching the target value is indicated by an acoustic (if activated in menu) and an optic signal (tolerance marks ).

Optical signal:

The tolerance marks provide the following information:













	Target quantity exceeds defined tolerance
	Target quantity within defined tolerance
	Target quantity below defined tolerance

Acoustic signal:

The acoustic signal depends on the menu setting `<SETUP → BEEPER>`, see chap. 13.3.1.

Procedure:

1. Define target quantity and tolerances

	⇒ Make sure that the scale is in counting mode and that an average piece weight has been defined (see chap. 11.2). If necessary, switch over with the  key.
	⇒ Call up menu setting < rEF >.
	⇒ Use the navigation keys ↓↑ to select the setting < tARGET > and confirm with → button.
	
	< VALUE > is displayed.
	⇒ Confirm on → button, the numeric input window appears. The active digit is flashing.
	⇒ Enter the target number of pieces (numerical input see chap. 3.2.2) and confirm the entry.
↓	
	The balance returns to the < VALUE > menu.
	⇒ Use the navigation buttons ↓↑ to select setting < ErruPP >.
	⇒ Confirm on → button, the numeric input window appears. The active digit is flashing.
	⇒ Enter the upper tolerance (for numerical entry see chap. 3.2.2) and confirm the entry.
↓	
	The balance returns to the < ErruPP > menu.
↓	

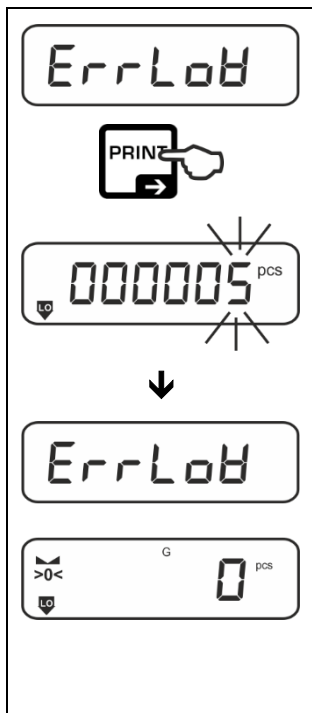

- ⇒ Use the navigation buttons ↓ to select setting < ErrLoB >.
- ⇒ Confirm on → button, the numeric input window appears. The active digit is flashing.
- ⇒ Enter the lower tolerance (for numerical entry, see chap. 3.2.2) and confirm the entry.
- ⇒ The balance returns to the < ErrLoB > menu.
- ⇒ Press repeatedly ←-button to exit menu.

Finished the setting works, the weighing balance will be ready for check counting.

2. Start tolerance check:

- ⇒ Determine the average item weight, see chap. 11.2.1
- ⇒ Place the weighed material and check by means of the tolerance marks / acoustic signal if the weighed material is within the defined tolerance.

Load below specified tolerance	Load within specified tolerance	Load exceeds specified tolerance

12 Application <Checkweighing>

12.1 Application-specific settings



Shouldn't the application <Checkweighing> already be enabled, select the menu setting < **Mode** → **check** >, see chap. 9

Call up menu:

- ⇒ Press the **TARE** key and hold it until < **APCnEr** > is displayed.
- ⇒ The display changes to < **check** > followed by < **target** >.
- ⇒ Navigation in menu see chap. 13.1

Overview:

Level 1	Level 2	Description / Chapter	
target Target weighing,	value	Target value entry	
	upper	Upper tolerance	
	lower	Lower tolerance	
	reset	Reset settings to factory defaults	
limits Checkweighing,	lower	Lower limit value, numeric input see chap. 3.2.2	
	upper	Upper limit value, numeric input see chap. 3.2.2	
	reset	Reset settings to factory defaults	
PRE-TARE PRE-TARE	actual	Take over the placed weight as PRE-TARE value, see chap. 10.2.1	
	manual	Numerical input of the tare weight, see chap. 10.2.2.	
	clear	Delete PRE-TARE value	
Mode Application mode	weigh	Weighing mode	see chap. 9.
	count	Counting mode	
	check	Check mode	

12.2 Using the application



12.2.1 Target weighing

The target weighing application allows weighing of goods within set tolerance limits in keeping with a determined target weight.

Reaching the target weight is indicated by an acoustic (if activated in menu) and an optic signal (tolerance marks).

Optical signal:

The tolerance marks provide the following information:

	Upper limit
	Target weight
	Lower limit

Acoustic signal:

The acoustic signal depends on the menu setting
<SETUP → BEEPER>, see chap. 13.3.1.

Procedure:

1. Define target weight and tolerances

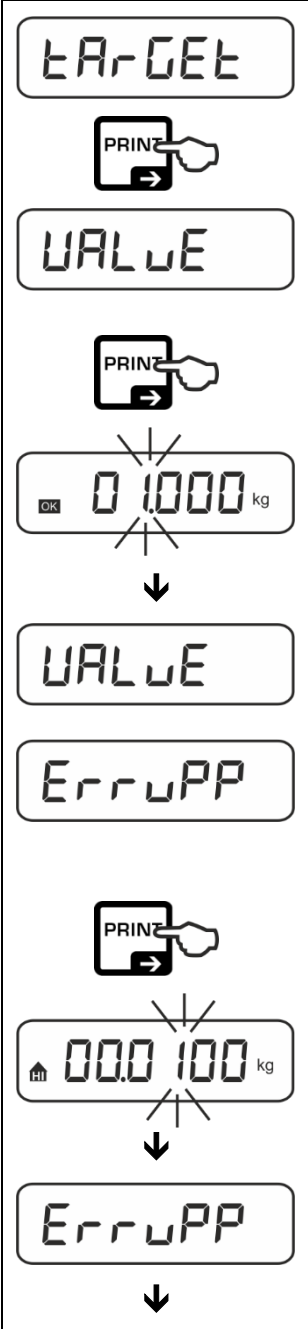

⇒ Use the navigation keys \uparrow to select the setting <TARGET> and confirm with \rightarrow button.

<VALUE> is displayed.

⇒ Confirm on \rightarrow button, the numeric input window appears. The active digit is flashing.

⇒ Enter target weight (numeric entry see chap. 3.2.2) and confirm the entry.

The balance returns to the <VALUE> menu.

⇒ Use the navigation buttons \uparrow to select setting <ErruPP>.

⇒ Confirm on \rightarrow button, the numeric input window appears. The active digit is flashing.

⇒ Enter the upper limit for the weight deviation (for numeric entry, see chap. 3.2.2) and confirm the entry.

The balance returns to the <ErruPP> menu.

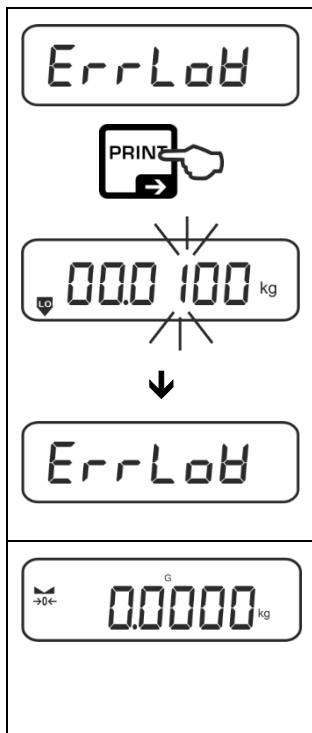

- ⇒ Use the navigation buttons ↓ to select setting <ErrLoB>.
- ⇒ Confirm on → button, the numeric input window appears. The active digit is flashing.
- ⇒ Enter lower limit for weight deviation (numeric entry see chap. 3.2.2) and confirm the entry.
- ⇒ The balance returns to the <ErrLoB> menu.
- ⇒ Press repeatedly ←-button to exit menu.

Finished the setting works, the weighing balance will be ready for checkweighing.

3. Start tolerance check:

- ⇒ Place the weighed material and check by means of the tolerance marks / acoustic signal if the weighed material is within the defined tolerance.

Load below specified tolerance	Load within specified tolerance	Load exceeds specified tolerance



12.2.2 Checkweighing

With the **<Checkweighing>** application you can check if the weighing good is within a predefined tolerance range.

When limit values are exceeded below or above, an acoustic signal (if enabled in menu) will sound and an optical signal (tolerance marks) will be displayed

Optical signal:

The tolerance marks provide the following information:

	Weighed-in goods exceed predefined tolerance
	Weighed-in goods within predefined tolerance
	Weighed-in goods below predefined tolerance

Acoustic signal:

The acoustic signal depends on the menu setting **<SETUP → BEEPER >**, see chap. 13.3.1.

Procedure:

1. Define limit values

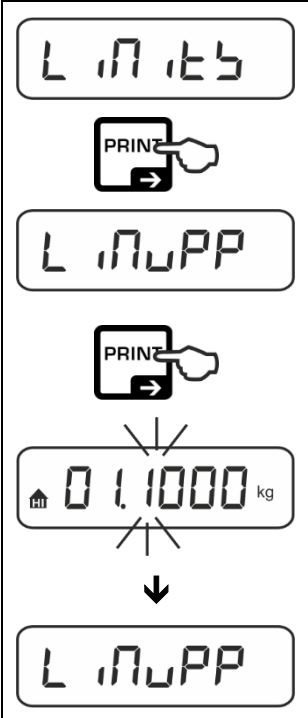

⇒ Use the navigation keys **↑** to select the setting **<L 1115 >** and confirm with **→** button.

<L 1100 > will appear.

⇒ Press **→** button to confirm, the numeric input window for entering the upper limit value will appear. The active digit is flashing.

⇒ Enter upper limit value (numerical input see chap. 3.2.2) and confirm the entry.

The balance returns to the **<L 1100 >** menu.

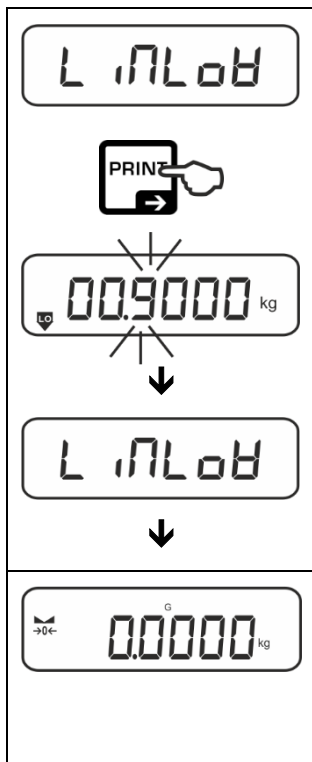

⇒ Use the navigation keys \uparrow to select setting <L 17LoB>.

⇒ Press \rightarrow button to confirm, the numeric input window for entering the lower limit value will appear. The active digit is flashing.

⇒ Enter lower limit value (numerical input see chap. 3.2.2) and confirm the entry.

The balance returns to the <L 17LoB> menu.

⇒ Press repeatedly \leftarrow -button to exit menu.

Finished the setting works, the weighing balance will be ready for checkweighing.

4. Start tolerance check:

⇒ Place the weighed material and check by means of the tolerance marks / acoustic signal if the weighed material is within the defined tolerance.

Load below specified tolerance	Load within specified tolerance	Load exceeds specified tolerance

13 Menu

13.1 Navigation in the menu

Call up menu:

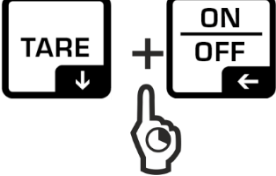
Application menu	Setup menu
 <p>Press the TARE button and keep it pressed until the first menu item will be displayed</p>	 <p>Press the TARE and ON/OFF button at the same time and keep them pressed until the first menu item will be displayed</p>

Select and adjust parameter:

Scrolling on one level	<p>Use the navigation buttons to select the individual menu blocks one by one.</p> <p>Use the navigation key ↓ to scroll down.</p> <p>Use the navigation key ↑ to scroll up.</p>
Activate menu item / Confirm selection	Press navigation key →
Menu level back / back to weighing mode	Press navigation key ←

13.2 Application menu

The application menu allows you a fast and targeted access to the respectively selected application (see chap. 9.).



An overview of the application-specific settings you will find in the description of the respective application.

13.3 Setup menu

In the setup menu you have the possibility to adapt the behaviour of the balance to your requirements (e.g. environmental conditions, especial weighing processes).

These settings are global and do not depend on the selected application.

13.3.1 Overview < SETUP >

Level 1	Level 2	Level 3	Level 4 / Description
		Description	
cAL Adjustment	cALEHt	→	External adjustment, see chap. 7.8.1
	cALEud	→	External adjustment, user-defined, see chap. 7.8.2
	GrARdJ	→	Gravity constant adjustment site, see chap.7.8.3
	GrAubE	→	Gravity constant installation site, see chap. 7.8.4
com Communication	rs232 ↕ usb-d ↕	bAud	300
			600
			1200
			2400
			4800
			9600
			14400
			19200
			38400
			57600
			115200
			128000
			256000
		dAtA	7db t5
			8db t5
		PAR t5	nonE
			odd
			EUEn
		StoP	1b t5
			2b t5
hAndsh	nonE		
Protoc	FCP		
	5cL (only selectable in USB)		
	BLAn	Not documented	

Print Data output	intFcE		rs232	RS 232 interface *			
			usb-d	USB interface* *only in connection with KUP interface			
	sum		on	Switch on / off add-up mode, see chap. 14.2.1			
			off				
	PrNode	trig	MANUAL	on, off Data output by pressing the PRINT button (see chap. 14.2.2)			
			Auto	on, off Automatic data output with a steady and positive weight value see chap. 14.2.3 Re-output only after zero display and stabilisation, depending on settings < ZERONE >, selectable (off, 1, 2, 3,4,5)			
		cont	off	Continuous data output			
			on	SPEED	Setting output interval see chap. 14.2.4.		
				ZERO	on, off 0 (unloaded) also transmit continuously		
				STABLE	on, off Transmit stable values only		
		WEIGHT	SGLPrE		on, off	Displayed weight value is transmitted	
			ContPrE	Grabb	on, off		
				net	on, off		
				ARE	on, off		
	FORmAt			Long (detailed measurement protocol) Short (standard measurement protocol)			
	LAYout	nonE		Standard layout			
		user	Model	on, off Output model designation of the scale			
			Serial	on, off Output serial number of the scale			
	RESET	Reset settings to factory defaults					

bEEPER Acoustic signal	AEYb	oFF	Switch on / off acoustic signal by pressing button		
		on			
	chEcH	ch-ofh	oFF	Acoustic signal off	
			SLob	Slow	
			StD	Standard	
			FASt	Fast	
			cont.	Continuous	
		ch-Lob	oFF	Acoustic signal off	
			SLob	Slow	
			StD	Standard	
			FASt	Fast	
		ch-h iCh	oFF	Acoustic signal off	
			SLob	Slow	
			StD	Standard	
	FASt		Fast		
	cont.		Continuous		
AutoFF Automatic switch-off function in rechargeable battery operation	noDE	oFF	Automatic switch-off function switched off		
		Auto	The balance is automatically switched-off according to the time without load change or without operation defined in menu item <t iNE >		
		onLY0	Automatic switch-off only with zero display		
	t iNE	30b	After the set time without load change or operation the balance will switch off automatically		
		10 in			
		20 in			
		50 in			
		300 in			
			600 in		

button Allocate function key	Not documented		
ቤ ስክ Display background illumination	በብይ	ALWAYS	Background lighting of display is switched on permanently
		ቲ ስቲ	The background illumination is automatically switched-off according to the time without load change or without operation defined in menu item < ቲ ስቲ >
		ብላ	Display background illumination always switched off
	ቲ ስቲ	5s	Definition, after which time the background illumination is automatically switched-off without load change or without operation.
		10s	
		30s	
		1ጠ ሰከ	
2ጠ ሰከ			
	5ጠ ሰከ		
	3ጠ ጠ ሰከ		
ቲ ለገገ Taring range	100% ↕ 10%	Definition max. taring range, selectable 10% - 100%. Numerical input, see chap. 3.2.2.	
ጊገገ Zero tracking	ብ	Automatic zero tracking [≤3d]	
	ብፍፍ	i	In the event that small quantities are removed or added to the material to be weighed, incorrect weighing results can be displayed due to the “stability compensation”. (e.g. slow flow of liquids from a container placed on the balance, evaporating processes). When apportioning involves small variations of weight, it is advisable to switch off this function.
ህ ኒ Units	selectable units, see chap. 1	Here is determined which units must be available in menu <unit>. Using  button, you can switch over to the units set to .	
	FFA	Weighing with multiplication factor, see chapter 10.2.5	
	mol	Mol weighing mode, see chap. 10.2.6	
በብይ Applications see chap. 9.	ቃ ስክ	Application <Weighing>	
	ቃህቲ	Application <Counting>	
	ቃክገገ	Application <Checkweighing>	
ገገገ	Reset balance settings to factory settings		

14 Communication with peripheral devices via KUP connection

Via the interfaces weighing data may be exchanged with connected peripheral devices.

Issue may be made to a printer, PC or check displays. In reverse order, control orders and data inputs may be made via the connected devices.

The balances of the DS series are equipped with a KUP connection (KERN Universal Port) as per standard.

The following options are available as interfaces:

Interface adapter with cable	
Interface examples	Application examples
RS232	Serial printer
USB	PC



The available interfaces can be used in parallel using the KUP Extension Box.

Connector assignment balance:

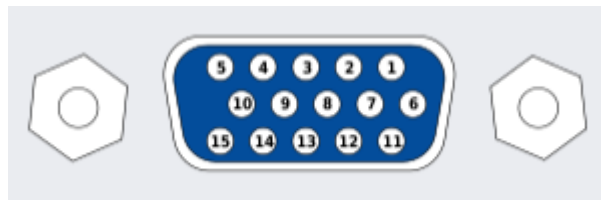

Warning: Only for use with KUP interfaces

14.1 KERN Communications Protocol (KERN Interface Protocol)

KCP is a standardized set of interface orders for KERN balances, which allows many parameters and device functions to be called up and controlled. KERN devices that have KCP can use it to connect easily to computers, industrial control systems and other digital systems. A detailed description you will find in the „KERN Communications Protocol“ manual, available in the download area on our KERN homepage (www.kern-sohn.com).

To activate KCP please observe the menu overview of your balance’s operating instructions.

KCP is based on simple ASCII orders and replies. Every interaction consists of an order, possibly with arguments separated by spaces and finished by <CR>< LF>.

The KCP orders supported by your balance may be queried emitting the order „I0“ followed by CR LF.

Extract of the mostly used KCP orders:

I0	Shows all implemented KCP orders
S	Sending stable value
SI	Sending current value (also instable)
SIR	Sending current value (also instable) and repeating
T	Taring
Z	Zeroing

Example:

Order	S	
Possible replies	S_ S_.....100.00_g S_l S_+ or S_-	Order accepted, execution of the order started, currently another order is executed, timeout reached, over- or underload

14.2 Issue functions

14.2.1 Add-up mode < sum >

With this function the individual weighing values are added into the summation memory by pressing a button and edited, when an optional printer is connected.

Activate function:

- ⇒ In Setup menu invoke the menu setting <Pr Mode → SUB1 > and confirm with button →.
- ⇒ Use the navigation keys ↓↑ to select the setting <on> and confirm on → button.
- ⇒ To exit the menu press the navigation key ← repeatedly



Condition: Menu setting <Pr Mode → NORMAL → on >

Add-up weighed goods:

- ⇒ If required, place empty container on scale and tare.
- ⇒ Place first good to be weighed on balance. Wait until stability display (▲▲) appears and then press the PRINT-button. The display changes to < SUB1 | >, followed by the current weighing value. The weighing value is stored and edited by the printer. The symbol Σ pops up. Remove the weighed good.
- ⇒ Place second good to be weighed on balance. Wait until stability display (▲▲) appears and then press the PRINT-button. The display changes to < SUB2 >, followed by the current weighing value. The weighing value is stored and edited by the printer. Remove the weighed good.
- ⇒ Add-up more weighed goods as described above.
- ⇒ You can repeat this process until the capacity of the scales is exhausted.

Display and edit sum „Total“:

- ⇒ Press the **PRINT** key long time. The number of weighings and the total weight are edited. The sum memory is deleted; the symbol [.Σ.] extinguishes.

Sample log (KERN YKB-01N):

Menu setting PrNode → BE iGht →
GntPrt → on & ForNAt → Short

No.			1	←		First weighing
N:	S S	1.9993 kg				
T:		0.0000 kg				
G:		1.9993 kg				
C:		1.9993 kg				
No.			2	←		Second weighing
N:	S S	0.9992 kg				
T:		0.0000 kg				
G:		0.9992 kg				
C:		2.9985 kg				
No.			3	←		Third weighing
N:	S S	0.4992 kg				
T:		0.0000 kg				
G:		0.4992 kg				
C:		3.4977 kg				
No.			3	←		Number of weightings/ Total
C:		3.4977 kg				

Sample log (KERN YKB-01N):

Menu setting PrNode → BE iGht → SCLPrt →

No.			1	←		First weighing
C:	200.0 g					
No.			2	←		Second weighing
C:	500.0 g					
No.			3	←		Third weighing
C:	700.0 g					
No.			4	←		Fourth weighing
C:	1100.0 g					
No.			4	←		Number of weightings/ Total
C:	1200.4 g					
No.			4	←		
C:	1200.4 g					

14.2.2 Data output after pressing the PRINT button < MANUAL >

Activate function:

- ⇒ In Setup menu invoke the menu setting <Print → PrintMode → Erase > and confirm with → button.
- ⇒ For a manual data output select the menu setting < MANUAL > with the navigation keys ↓↑ and confirm on the → button.
- ⇒ Use the navigation keys ↓↑ to select the setting <on > and confirm on → button.
- ⇒ To exit the menu press the navigation key ← repeatedly.

Place goods to be weighed on balance:

- ⇒ If required, place empty container on scale and tare.
- ⇒ Place goods to be weighed. The weighing value is edited by pressing the PRINT-button.

14.2.3 Automatic data output < AUTO >

Data output happens automatically without having to press the **PRINT**-key as soon as the corresponding output condition has been met, dependent on the setting in the menu.

Enable function and set the output condition:

- ⇒ In Setup menu invoke the menu setting <Print → PrintMode → Print > and confirm with → button.
- ⇒ For an automatic data output select the menu setting < AUTO > using the navigation keys ↓↑ and confirm by the → button.
- ⇒ Use the navigation keys ↓↑ to select the setting < on > and confirm on → button. < AUTO > is displayed.
- ⇒ Acknowledge by →-button and set the required output condition with the navigation keys ↓↑.
- ⇒ Acknowledge by →-button.
- ⇒ To exit the menu press the navigation key ← repeatedly.

Place goods to be weighed on balance:

- ⇒ If required, place empty container on scale and tare.
- ⇒ Place weighed goods and wait until the stability display (▲▲) appears. The weighing value is issued automatically.
- ⇒

14.2.4 Continuous data output < CONT >

Enable function and set the output interval:

- ⇒ In Setup menu invoke the menu setting <Print → PrintMode → Print > and confirm with → button.
- ⇒ For a continuous data output select the menu setting < CONT > using the navigation keys ↓↑ and confirm on → button.
- ⇒ Use the navigation keys ↓↑ to select the setting < on > and confirm on → button.
- ⇒ < SPEED > is displayed.
- ⇒ Acknowledge with the →-button and set the required time interval with the navigation keys ↓↑ (numeric input see chap. 3.2.2)
- ⇒ < ZERO > & < ENABLE > set the required output condition.
- ⇒ To exit the menu press the navigation key ← repeatedly.

Place goods to be weighed on balance

- ⇒ If required, place empty container on scale and tare.
- ⇒ Place goods to be weighed.

⇒ The weighing values are issued according to the defined interval.

Sample log (KERN YKB-01N):

S	D	1.9997	kg
S	D	1.9999	kg
S	D	1.9999	kg
S	D	1.9999	kg
S	S	2.0000	kg
S	S	2.0000	kg
S	S	2.0000	kg
S	S	2.0000	kg
S	D	1.9998	kg
S	D	1.9998	kg
S	D	2.0002	kg
S	D	2.4189	kg
S	D	2.9998	kg
S	D	2.9996	kg
S	D	2.9996	kg
S	D	2.9997	kg
S	D	2.9997	kg
S	S	2.9996	kg
S	S	2.9996	kg

14.3 Data format

- ⇒ In the setup menu call up the menu setting <Print → PrMODE → BEIGHT → ContPrbt> and confirm with key →.
- ⇒ Use the navigation keys ↓↑ to select the menu setting <FORMAT > and confirm on → button.
- ⇒ Use the navigation buttons ↓↑ to select the desired setting.
Options:
 - <Short > Standard measuring protocol
 - <Long > Detailed measuring protocol
- ⇒ Confirm setting with →-button.
- ⇒ To exit the menu press the navigation key ← repeatedly.

Sample log (KERN YKB-01N):

FORMAT → Short		FORMAT → Long	
N:	S S	2.0000	kg
T:		0.5000	kg
G:		2.5000	kg
N:	S D	2.0000	kg
Tara weight after x:		0.5000	kg
Gross weight:		2.5000	kg

15 Servicing, maintenance, disposal



Before any maintenance, cleaning and repair work disconnect the appliance from the operating voltage.

15.1 Cleaning

Please do not use aggressive cleaning agents (solvents or similar agents), but a cloth dampened with mild soap suds. Ensure that no liquid penetrates into the device. Polish with a dry soft cloth.

Loose residue sample/powder can be removed carefully with a brush or manual vacuum cleaner.

Spilled weighing goods must be removed immediately.

15.2 Servicing, maintenance

- ⇒ The appliance may only be opened by trained service technicians who are authorized by KERN.
- ⇒ Before opening, disconnect from power supply.

15.3 Disposal

Disposal of packaging and appliance must be carried out by operator according to valid national or regional law of the location where the appliance is used.

16 Instant help for troubleshooting

In case of an error in the program process, briefly turn off the balance and disconnect from power supply. The weighing process must then be restarted from the beginning.

Fault	Possible cause
The weight display does not glow.	<ul style="list-style-type: none">• The balance is not switched on.• The mains supply connection has been interrupted (mains cable not plugged in/faulty).• Power supply interrupted.
The displayed weight is permanently changing	<ul style="list-style-type: none">• Draught/air movement• Table/floor vibrations• Weighing plate has contact with foreign objects.• Electromagnetic fields / static charging (choose different location/switch off interfering device if possible)
The weighing result is obviously incorrect	<ul style="list-style-type: none">• The display of the balance is not at zero• Adjustment is no longer correct.• The balance is on an uneven surface.• Great fluctuations in temperature.• Warm-up time was ignored.• Electromagnetic fields / static charging (choose different location/switch off interfering device if possible)

17 Error messages

Error message	Explication
0L n t	Zero setting range exceeded
undEr0	Zero setting range not achieved
instAb	Load instable
ErOnG	Adjustment error
L _ _ _ J	Underload
[_ _ _]	Overload
Lo bAt	Capacity of batteries / rechargeable batteries exhausted