

XXX
NON-OVERLAP

TS96



The TS96 addresses the needs of the professional contractor looking for high production finishing. The reduced maintenance, low profile ride-on power trowel features a responsive steering system and heavy duty gearbox. The TS96 delivers high rotor speeds suited for finish applications, yet ideal for float pan operations.

Features

- ✓ Heavy duty gearbox provides lower operating temperature and longer life.
- ✓ Variable speed clutch and pulley drive system produces consistent blade speed up to 180 rpm.
- ✓ Dependable air-cooled Briggs & Stratton 35 hp engine provides consistent power.
- ✓ Low machine profile offers increased machine stability and a better view of the work surface.
- ✓ Flip-up end rings facilitate efficient blade changes.
- ✓ Flip-up seat reveals a sturdy lifting bale for ease of transport and to facilitate engine maintenance.
- ✓ Twin stick, multi-directional steering system provides precision control and full maneuverability.
- ✓ Engine hour meter to monitor periodic maintenance, adjustable operator's seat for greater comfort, and a set of four 50 watt lights to improve visibility in poorly lit conditions are standard features.

Ride-On Power Trowel

TS96

XX

NON-OVERLAP

Options

- ✓ Factory installed Retardant Spray System.
- ✓ Job site transporter.

Performance Characteristics

Trowel RPM (maximum)	180 rpm
Trowel RPM (normal)	170-190 rpm
Travel speed (maximum)	380 ft/min (116 m/min)
Engine	24HP, electric start, air cooled V-twin
Fuel capacity	2.9 gal (11L)
Est. Running Time	2.75 hours
Weight (dry)	905 lbs (410 kg)
Weight (operating)	950 lbs (431 kg)
Sound power	105Db
Vibration	<2.5m/s ²

Dimensions

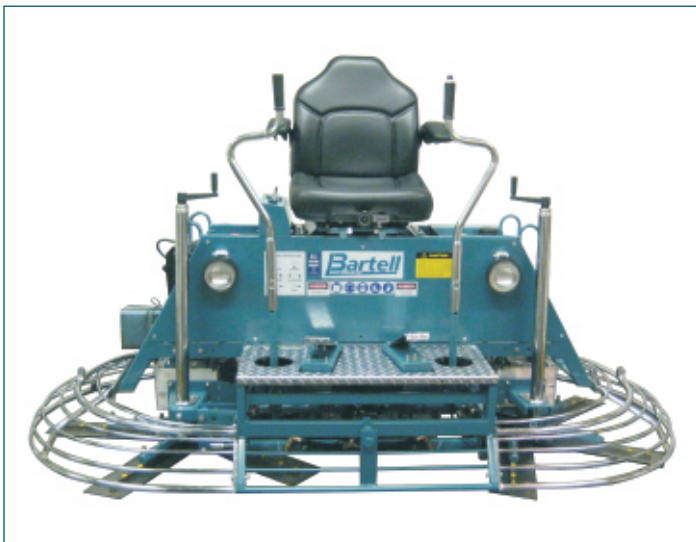
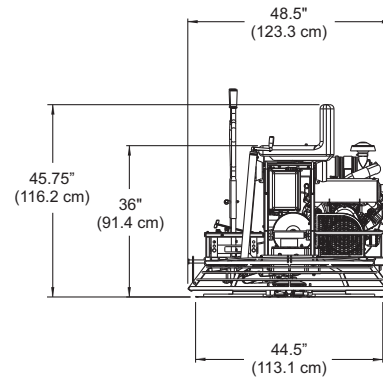
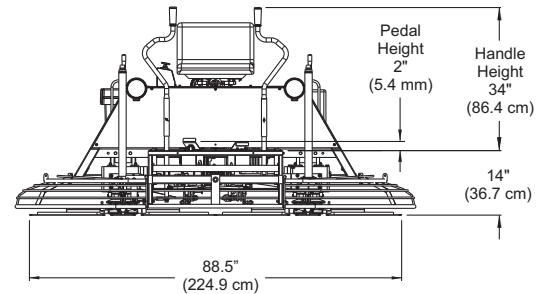
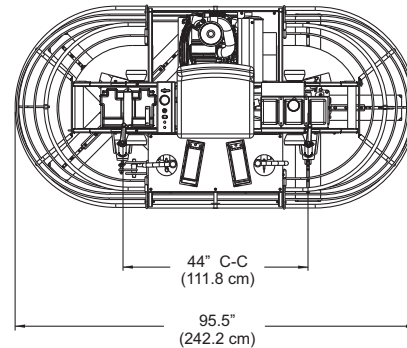

For more information, product demonstration, or details on purchase, lease and rental plans, please contact your local BMI Dealer.

BARTELL MORRISON INC.

31 Sun Pac Blvd., Brampton, ON Canada L6S 5P6
 Tel 866-501-1683 • Local 905-458-5455 • Fax 905-458-5484
 www.bartellmorrison.com • sales@bartellmorrison.com

