

ISM

SPARE PARTS LIST

1 Spare parts list

POS.	PAGE	CODE	DESCRIPTION	TYP (*)	REMARK
1	P0801	00310004615	Spring clip for blade guard cover	S	
2	P0801	00310004706	Depth feed handle with rubber grip	S	
3	P0801	00310004193	Rubber grip	S	
4	P0801	00310004281	Blade guard cover hinge	S	
5	P0801		Blade guard cover only	S	
6	P0801	00310004700	Blade guard cover assembly	S	
7	P0802	00310004707	Depth feed reducer crank	S	
8	P0802	00310002114	Foot pedal spring assembly	S	
10	P0802	00310004285	Depth feed screw protection	S	
11	P0802	00310004711	Depth feed reducer operating rod	S	
12	P0802	00310004159	Plug	W	
13	P0802	00310004710	Depth feed reducer	S	
14	P0802	00310004293	Guide-a-cut rail	W	
15	P0801	00310004725	Belt guard	S	
16	P0801		Locking screw	S	
17	P0801	00310004188	Electric motor	S	
62	P0801	00310004250	Connecting box	S	
63	P0801	00310005894	Connecting bolts	S	
64	P0801	00310004251	Fan	S	
65	P0801	00310004274	Fan cover	S	
18	P0801	00310002084	Adjusting ring	S	
19	P0801	00310004613	Cutting head pivot bearing	S	
20	P0801	00310004305	Draw spring	S	
21	P0802	00310002129	Cutting head rubber stop assy	W	
22	P0802		Depth feed bearing	W	
23	P0802	00310004288	Connecting bar	W	
24	P0802	00310004287	Connecting bar casting	S	
25	P0802	00310004168	Plunger for connecting bar casting	S	
71	P0802	00310004214	Spring only	S	
26	P0802	00310002128	Adjust a cut cable	W	
27	P0802	00310004167	Adjust a cut knob	S	
28	P0802	00310003989	Foot pedal	S	
29	P0801	00310004106	Cutting head welded	S	
30	P0801	00310004713	Engine shaft pulley	S	
31	P0801	00310004311	V Belts (set of 4)	W	
32	P0801	00310005308	Switch complete	W	
33	P0801		Tensioning screw	S	
34	P0801	00310004280	Blade shaft screw	S	
35	P0801	00310004176	Outside blade collar	S	
36	P0801	00310004210	Inner collar	S	
37	P0801	00310004196	Inner blade collar key	S	
38	P0801	00310004295	Blade shaft bearing	W	
39	P0801	00310004278	Blade shaft only	S	

40	P0801	00310004624	Blade shaft pulley with key	S	
41	P0801	00310004699	Blade shaft assembly	S	
42	P0801	00310002126	Water nozzles (set of 2)	W	
43	P0801	00310002085	Water cock	W	
44	P0801	00310004182	Spider	W	
47	P0801		Water hose	W	
48	P0801	00310004696	Water curtain	W	
49	P0802		Drain plug assembly	S	
50	P0802	00310004160	Female plug	W	
51	P0802	00310004199	Key 22mm	S	

(*): S = Spare part, W = Wear part

Wear parts are worn out through normal use of the machine. The wear period depends a lot on the intensity of use of the machine. Wear parts must be serviced, used and eventually changed following the indications of the manufacturer. Any wear due to normal use of the machine will not be considered as a case of warranty. Genuine Clipper replacement parts should always be used.

2 Exploded parts drawings
EC01

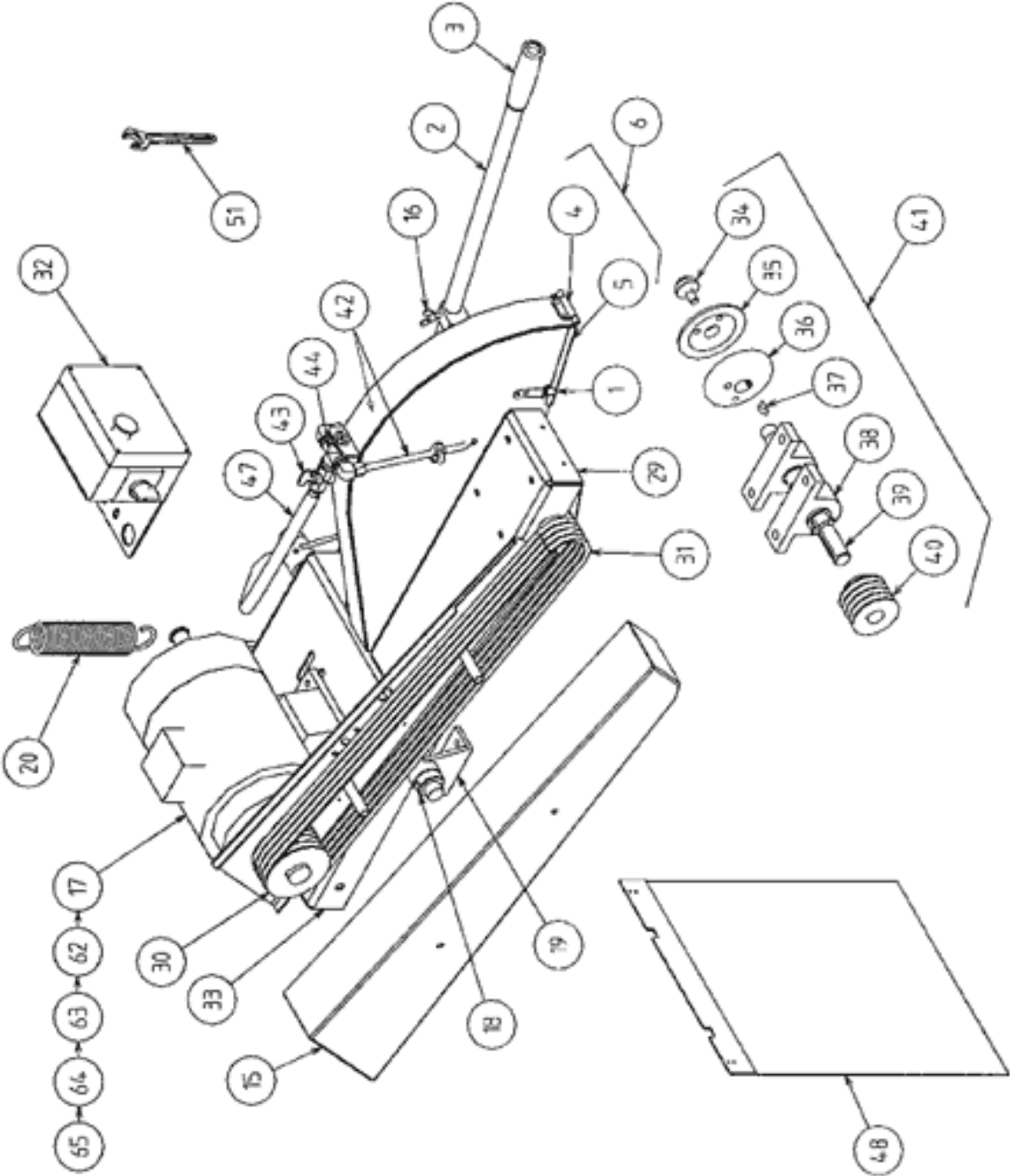

3 Exploded drawings and spare parts list for electrical equipment

REP.	CODE	DESCRIPTION
1	00310006622	Main switch
2	00310006618	Star-triangle switch
3	00310006617	Relay

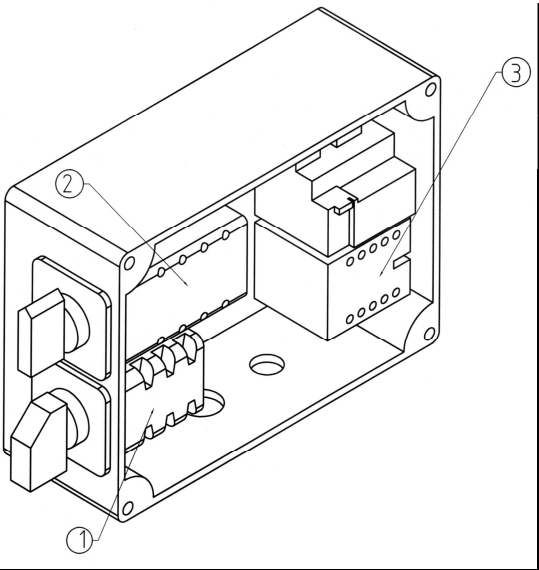



SAINT-GOBAIN ABRASIVES

190, Bd. J. F. Kennedy
L-4930 BASCHARAGE
LUXEMBOURG

Tel.: ++352 50401-1

Fax: ++352 501633

e-mail: sales.nlx@saint-gobain.com

www.construction.norton.eu

29.09.2008