



## Peltier-cooled incubator IPP55plus

Microbiology, zoology, food, cosmetics or pharma industry: the energy-saving cooled incubator with Peltier elements heats up and cools down seamlessly in one system.



With the help of our model selection, with dimensioned model sketches and extensive technical data for download, you will find your perfect Peltier-cooled incubator. For large volumes in conjunction with rapid temperature changes, the Memmert compressor-cooled incubator is recommended. Flexibility and technical features of our appliances meet all possible needs. Put us to the test!

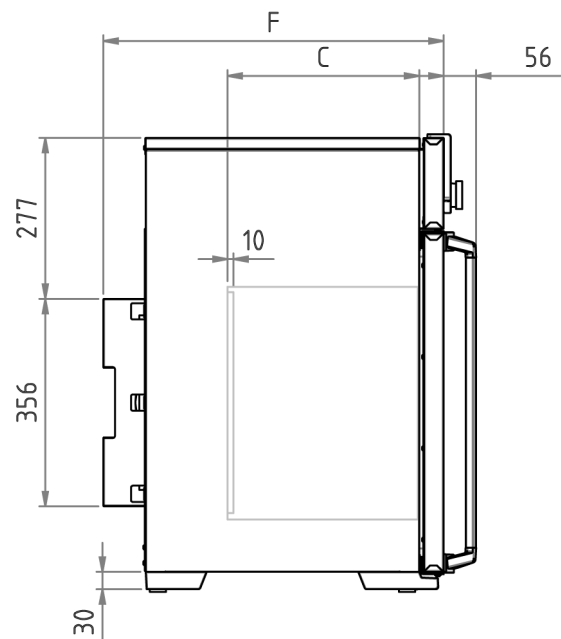
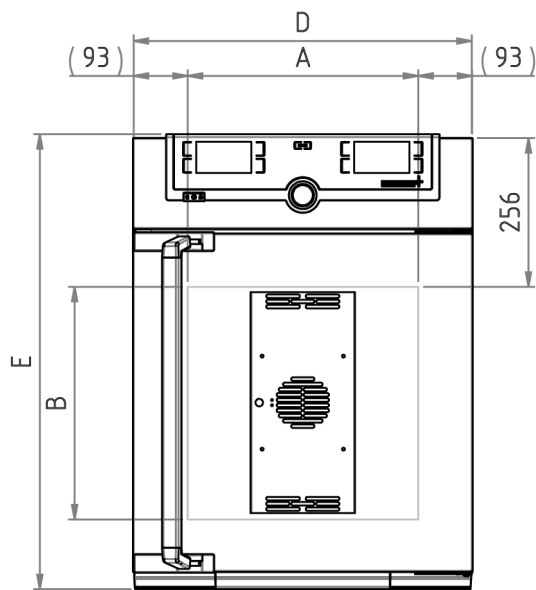

## Temperature

**Working temperature range** from 0°C to +70°C

**Setting accuracy temperature** 0.1°C

**Temperature** 2 Pt100 sensors Class A in 4-wire-circuit, mutually monitoring and taking over the performance at the same temperature value

## Control technology

**ControlCOCKPIT** TwinDISPLAY. Adaptive multifunctional digital PID-microprocessor controller with 2 high-definition TFT-colour displays.

**Language setting** German, English, Spanish, French, Polish, Czech, Hungarian

**Timer** Digital backwards counter with target time setting, adjustable from 1 minute to 99 days

**Function SetpointWAIT** the process time does not start until the set temperature is reached

**Calibration** three freely selectable temperature values

**adjustable parameters** temperature (Celsius or Fahrenheit), programme time, time zones, summertime/wintertime

## Ventilation

**Convection** forced ventilation by Peltier fan

## Communication

**Documentation** programme stored in case of power failure

**Programming** AtmoCONTROL software on a USB stick for programming, managing and transferring programmes via Ethernet interface or USB port

## Safety

**Temperature control** over- and undertemperature monitor TWW, protection class 3.3 or adjustable temperature limiter TWB, protection class 2, selectable on display

**AutoSAFETY** additionally integrated over- and undertemperature protection "ASF", automatically following the setpoint value at a preset tolerance range, alarm in case of over- or undertemperature, heating function is switched off in case of overtemperature, cooling function in case of undertemperature

**Autodiagnostic system** for fault analysis

**Alarm** visual and acoustic

## Heating concept

**Peltier** Heating and cooling performance distribution by individual control of the Peltier elements in the upper and lower row

**Peltier** energy-saving Peltier heating-/cooling system integrated in the rear (heat pump principle)

## Standard equipment

<b>Scope of delivery</b>	incl. works calibration certificate for +10°C and +37°C
<b>Door</b>	fully insulated stainless steel door with 2-point locking (compression door lock)
<b>Door</b>	inner glass door
<b>Internals</b>	1 stainless steel grid

## Stainless steel interior

<b>Volume</b>	53 l
<b>Dimensions W x H x D in mm</b>	$w_{(A)} \times h_{(B)} \times d_{(C)}$ : 400 x 400 x 330 mm
<b>Max. number of internals</b>	4
<b>Max. loading of chamber</b>	80 kg
<b>Max. loading per internal</b>	20 kg

## Textured stainless steel casing

<b>Dimensions</b>	$w_{(D)} \times h_{(E)} \times d_{(F)}$ : 585 x 784 x 604 mm
<b>Housing</b>	rear zinc-plated steel

## Electrical data

<b>Voltage</b>	230 V, 50/60 Hz
<b>Electrical load</b>	approx. 275 W
<b>Voltage</b>	115 V, 50/60 Hz
<b>Electrical load</b>	approx. 275 W

## Packing/shipping data

the appliances must be transported upright

<b>Customs tariff number</b>	8419 8998
<b>Country of origin</b>	Federal Republic of Germany
<b>WEEE-Reg.-No.</b>	DE 66812464
<b>Dimensions approx incl. carton</b>	B x H x T: 730 x 950 x 670 mm
<b>Net weight</b>	approx. 52 kg
<b>Gross weight carton</b>	approx. 71 kg

Standard units are safety-approved and bear the test marks

