

Machine platens selection (necessary accessories):

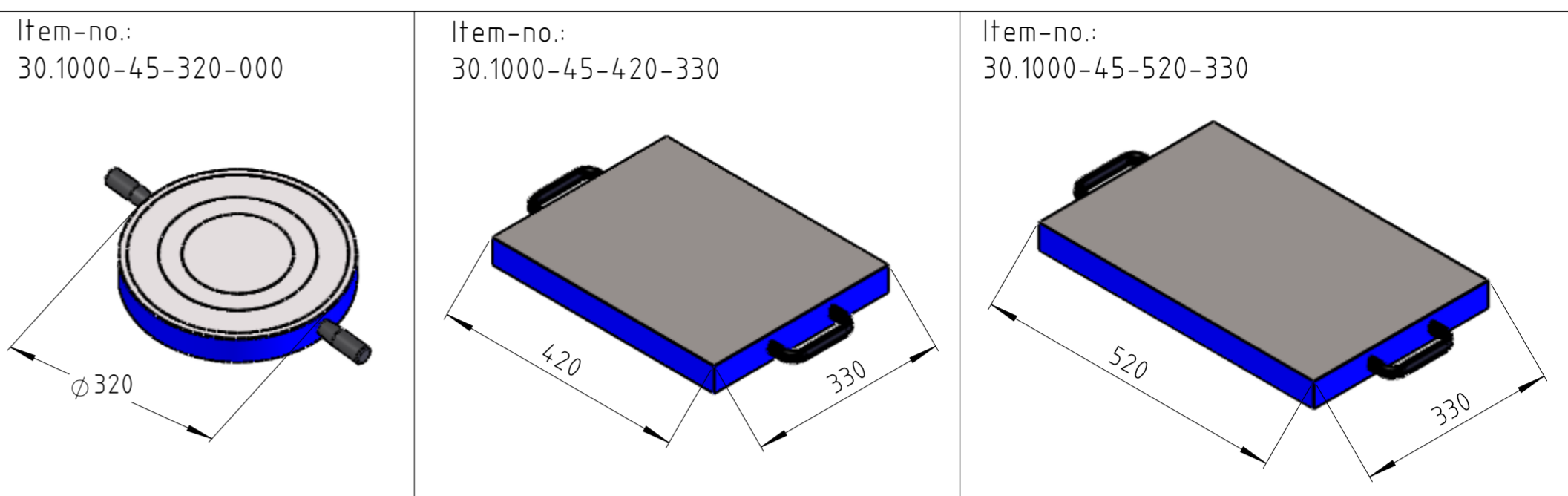

optional accessories:

Side table - 22.1101.01-10:  
for left or right side  
with ball rolls to move heavy samples or device easily  
into the test chamber

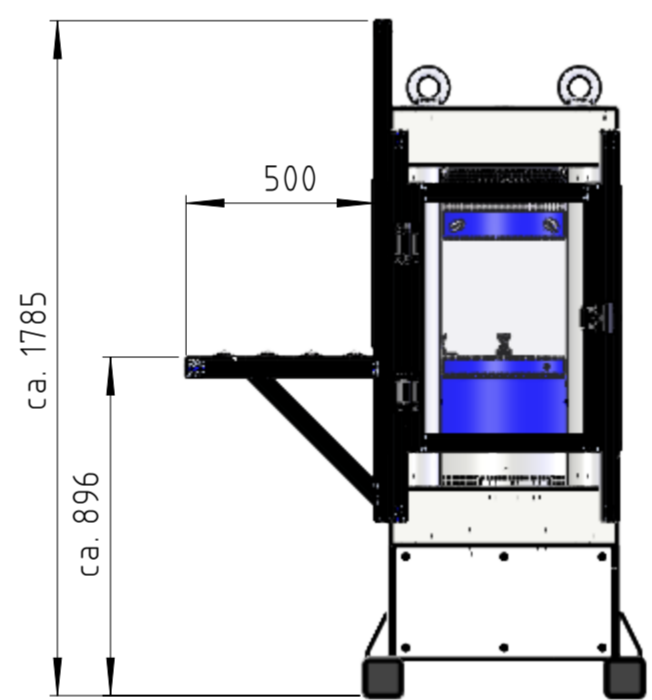

Auxiliary platens set - 30.0700 consisting of:  
1 piece 210 x 210 x 50 - 30.0701  
1 piece 160 x 160 x 75 - 30.0702  
for cubes 200 and 150 mm

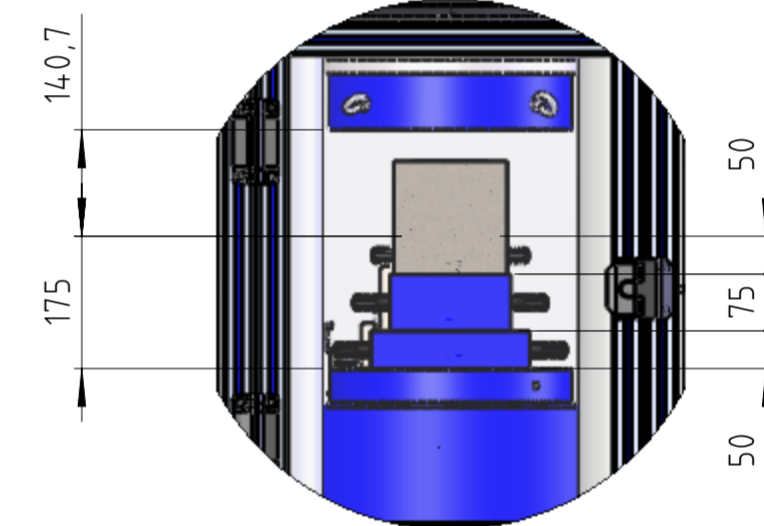

for testing cubes 100 mm is required a further  
auxiliary platen:  
30.0703 - 110 x 110 x 50 mm

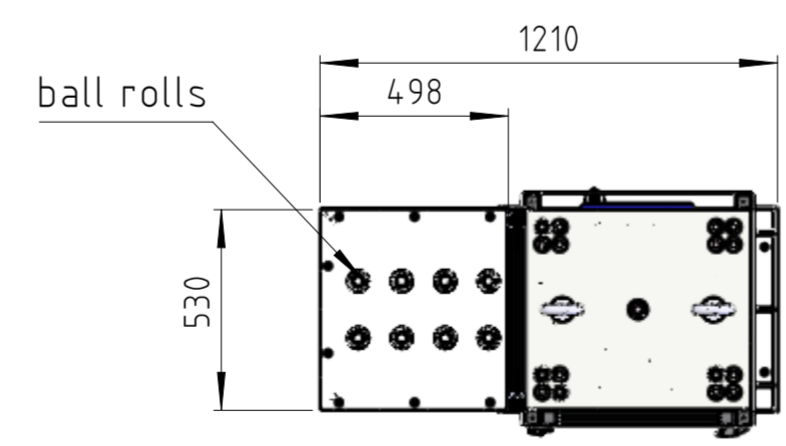

Measurement system - 22.11XX-WMS:  
mounted at the back of the  
plunger cylinder  
MTS R-Serie  
interface SSI  
resolution 0,001 mm

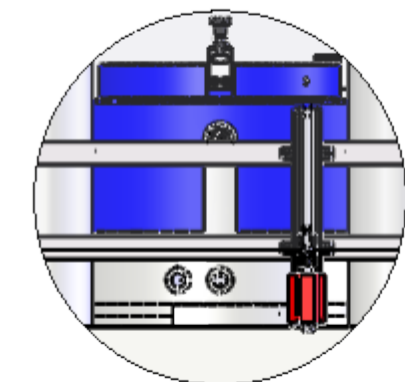

technical facts - BD 3000 H100:  
Item no.: 22.1101.01-FU-i20  
ball-seating acc. strain gauged procedure  
indication range: 0- 3000 kN  
measuring range: 100 - 3000 kN, class 1  
piston stroke: 100 mm  
test chamber height: 315 mm (other  
possible)  
distance between columns:  
front: 340 mm  
side: 270 mm

Rev. Änderung		Datum		Name	
TESTING Blühm & Feuerherdt GmbH Notzener Straße 26 b D-12277 Berlin Tel.: +49/30/710 96 45-0 Fax: +49/30/710 96 45-97 e-mail: info@testing.de		Maßstab: 1:20	Oberflächen nach DIN ISO 1302	Werkstückkanten nach DIN ISO 13715	Allgemeintoleranzen DIN ISO 2768 m / K
DATUM		NAME		Bezeichnung	
Bearb. 09.03.2020		p.sonnwald		Compression frame 3000kN BD 3000 H100 with frequency converter and EDCi	
Gepr.				Zeichnungsnummer	
Status		IN ARBEIT		22.1101.01-FU-i20	
Material:				Rev:	
Oberflächenbeschichtung:				A2	
Gewicht [kg]: 2264.19		Dateiname: Layout_22.1101.01-FU-i20		Blatt: 2 / 2	

Ohne unsere vorherige Zustimmung darf diese Übertragung weder vervielfältigt noch Dritten zugänglich gemacht werden und sie darf nicht zum Empfänger über Dritte oder nachträglich in anderer Weise mit dem Hersteller verbunden werden.