

Machine platens selection (necessary accessories):

Standard  
30.1000-45-320-000

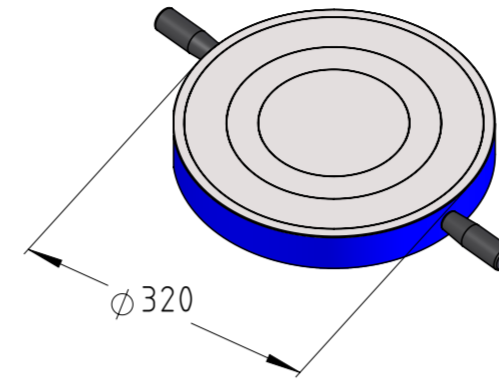

Optional  
22.1101-DP-420-330

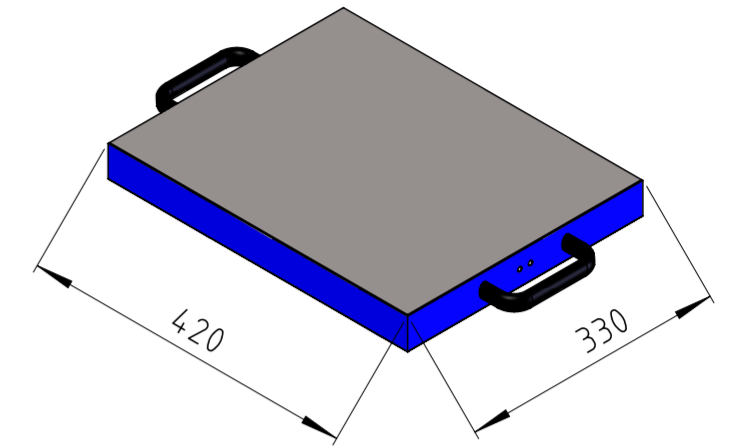

optional accessories:

Side table - 22.1101.01-10:  
for left or right side  
with ball rolls to move heavy samples or device easily  
into the test chamber including lift door

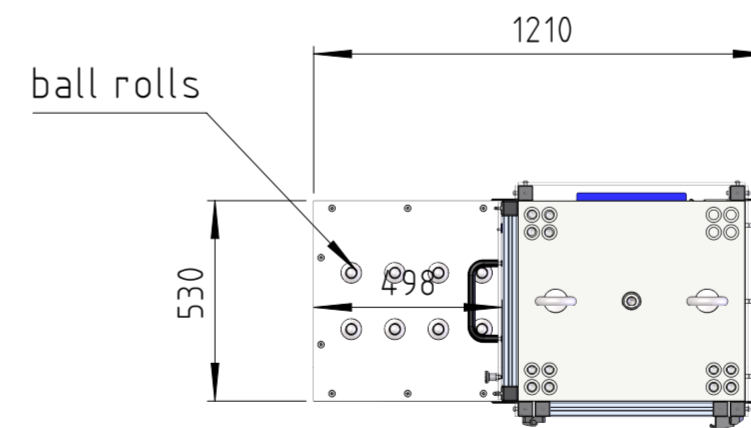
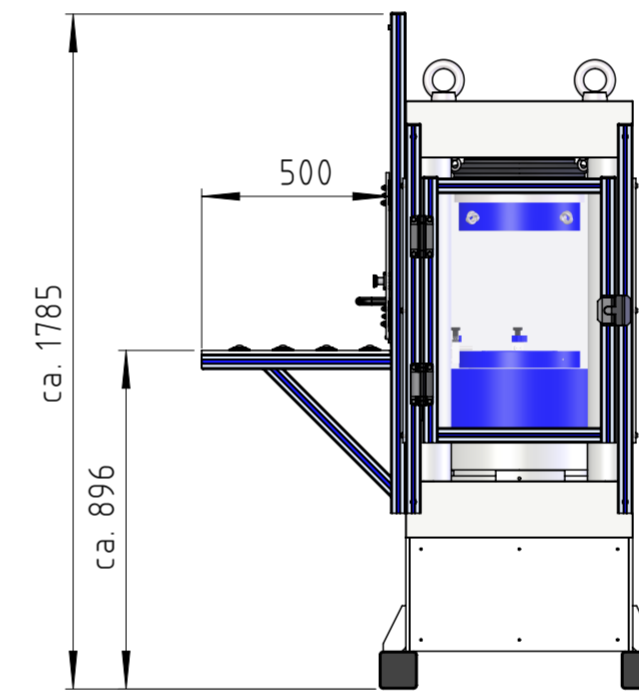

Auxiliary platens set - 30.0700 consisting of:  
1 piece 210 x 210 x 50 - 30.0701  
1 piece 160 x 160 x 75 - 30.0702  
for cubes 200 and 150 mm

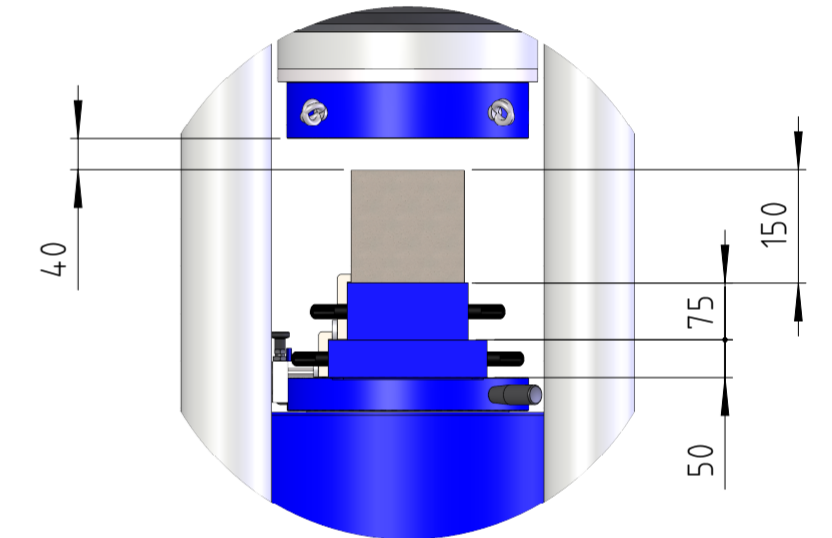

for testing cubes 100 mm is required a further  
auxiliary platen:  
30.0703 - 110 x 110 x 50 mm

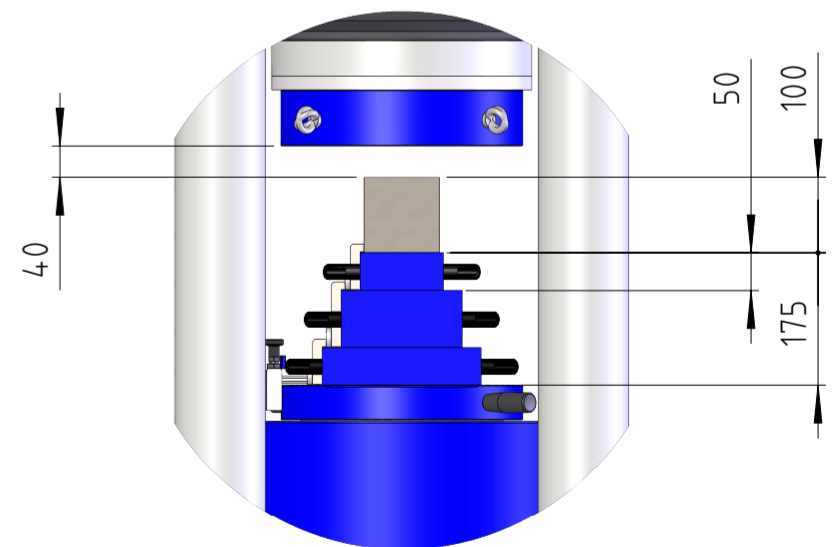

technical facts - BD 2000 H100:  
Item no.: 22.1100.01-TOUCH  
ball-seating acc. strain gauged procedure  
indication range: 0- 2000 kN  
measuring range: 80 - 2000 kN, class 1  
piston stroke: 100 mm  
test chamber height: 315 mm (other possible)  
distance between columns:  
front: 340 mm  
side: 270 mm

Rev.	Änderung	Datum	Name
TESTING	Bühm & Feuerherdt GmbH Mutzener Straße 26 b D-12277 Berlin Tel.: +49/30/710 96 45-0 Fax: +49/30/710 96 45-97 e-mail: info@testing.de		
Bearb.	12.11.2020	p.sonnwald	
Gepr.			
Status	IN ARBEIT		
Material:	-		
Oberflächenbeschichtung:			
Gewicht [kg]:	2261.21		

Maßstab:	1:20	Oberflächen nach DIN ISO 1302	Werksrückrahmen nach DIN ISO 13715	(1:10) $\pm 0.3$ $\pm 0.3$	Allgemeintoleranzen DIN ISO 2768 m / K
Bezeichnung	Compression frame 2000kN BD2000 H100 with frequency converter and Touch Controller				
Zeichnungsnummer	22.1100.01-TOUCH				Rev: A2
Dateiname:	22.1100.01-TOUCH_layout-1-2000kN-v1-en				Blatt: 2 / 2

Ohne unsere vorherige Zustimmung darf diese Übertragung weder vervielfältigt noch Dritten zugänglich gemacht werden und sie darf nicht für andere Zwecke als die, für die sie bestimmt wurde, verwendet werden.